



- **JP13-LP FAMILY**

- **JP13-LP, JP13-B-LP & JP13-S-LP GPS-
Receivers**

-  **Lead-free products**

- **Hardware description**

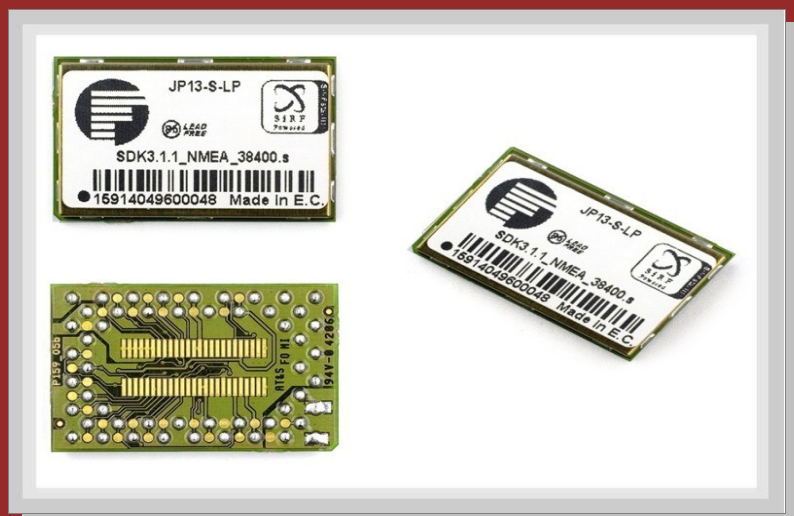

Index of contents

1 INTRODUCTION.....	6
1.1 General.....	6
1.2 Order options.....	7
1.3 Used abbreviations.....	8
1.4 Related documents.....	8
2 SECURITY.....	9
2.1 General information.....	9
2.2 Restricted use.....	9
2.3 Children.....	9
2.4 Operation/antenna.....	9
2.5 Electrostatic Discharge (ESD).....	9
3 SAFETY STANDARDS.....	10
4 TECHNICAL DATA.....	11
4.1 FEATURES.....	11
5 TECHNICAL DESCRIPTION.....	12
5.1 Receiver Architecture.....	12
5.2 Product applications.....	13
5.3 Technical specifications.....	13
5.3.1 Electrical Characteristics.....	13
5.3.1.1 General.....	13
5.3.1.2 Accuracy.....	13
5.3.1.3 DGPS Accuracy.....	13
5.3.1.4 Datum.....	13
5.3.1.5 Time to First Position.....	13
5.3.1.6 Sensitivity*.....	14
5.3.1.7 Dynamic Conditions.....	14
5.3.1.8 DC Power.....	14
5.3.1.9 Serial Port.....	14
5.3.1.10 Time – 1PPS Pulse.....	14
5.4 Power management modes overview	15
5.4.1 Normal Operation mode	15
5.4.2 Adaptive TricklePower mode (ATP).....	15
5.4.3 Push-to-Fix Mode	16
5.4.4 NMEA input message for ATP & PTF Mode.....	17
6 HARDWARE INTERFACE AND CONFIGURATION SIGNALS.....	19
6.1 Interfaces (pin-out) of the JP13-LP.....	19
6.2 Interfaces (ball assignment) of the JP13-B-LP.....	20
6.3 Interfaces (balls assignment) of the JP13-S-LP.....	22
6.4 Configuration and timing signals.....	23
7 SOFTWARE INTERFACE.....	25

7.1 SiRF binary data message.....25

7.2 NMEA data message.....26

7.2.1 NMEA output messages.....26

7.2.2 NMEA input messages.....26

7.2.3 Transport Message.....27

8 MECHANICAL DRAW.....28

9 LAYOUT RECOMMENDATION.....31

9.1 Ground planes.....31

9.2 RF connection.....31

10 FIRST STEPS TO MAKE IT WORKS.....33

11 APPENDIX.....35

11.1 How to set the target GPS receiver into power saving modes?.....35

VERSION HISTORY:

Version	Author	Changes	Release date
1.0.0	F. Beqiri	- Initial version	03/01/2007
1.0.1	F. Beqiri	- Updated soldering profile and added note– see Figure 17 , page 34 and read the note below.	20/06/2007
1.0.2	F. Beqiri	- JP13-LP module can accept only one reflow process.	26/09/2007

Cautions

Information furnished herein by FALCOM is believed to be accurate and reliable. However, no responsibility is assumed for its use. Also the information contained herein is subject to change without notice.

Please, read carefully the safety precautions.

If you have any technical questions regarding this document or the product described in it, please, contact your vendor.

General information about FALCOM and its range of products is available at the following Internet address: <http://www.falcom.de/>

Trademarks

Some mentioned products are registered trademarks of their respective companies.

Copyright

This description is copyrighted by FALCOM Wireless Communications GmbH with all rights reserved. No part of this user's guide may be produced in any form without the prior written permission of FALCOM Wireless Communications GmbH.

FALCOM Wireless Communications GmbH.

No patent liability is assumed with respect to the use of the information contained herein.

1 INTRODUCTION

1.1 General

This description is focussed on the GPS receiver of the FALCOM JP13-LP family series from FALCOM GmbH.

The JP13-LP family is an excellent device designed for a wide variety of system solutions and offers an easy integration in various ways on the user application platform. The JP13-LP family architecture based on a 0.13 micron CMOS process of the GSC3eLP chipset is a low-power version of the advanced SiRFstarIII receiver with increased to 20 parallel channels.

The JP13-LP family with the equivalent of more than 200,000 correlators used for processing signals, enables extremely fast and deep GPS signal search capabilities; achieving time-to-first-fix in only seconds; resulting a significant improvement on the GPS performance. The acquiring signals and accomplishment of getting fixes pushed in places never before expected, supporting a practical of real-time navigation for location based services, including in many indoor environments, through urban canyons.

The JP13-(S)-LP delivers major advancements in GPS performance, accuracy, integration, computing power and flexibility. The FALCOM JP13-LP family has an integrated temperature compensated crystal oscillators (TCXO). Due to the higher stability of frequency it offers a high-improved GPS performance. In addition, higher sensitivity allows it more flexibility on its design, the placement of the antenna and the selection of the kind of antenna. The physical interface to the unit application is made through edge pins, provided balls or integrated a 50-pin board-to-board connector. This is required for controlling the unit, receiving GPS location data, transferring data and providing power supply line. The JP13-LP family unit incorporates 8 megabits of flash memory required for storing the GPS software and user application programs and 1 megabit of static RAM.

The JP13-LP family consists of two members - the JP13-LP and JP13-S-LP. All products have identical electrical and RF-performance, however, offers different sizes, pin-out and mounting features to the target application platform. All GPS units introduce new generation of hardware and software.

The single board solution is offered as a 30-pin (24.6 mm x 15.7 mm) edge contacts and as a 48-pin (24.6 mm x 15.7 mm) BGA.

Compared to the JP13-LP, the JP13-S-LP is optimized for location applications requiring high performance in a very small form factor - ideal for devices with limited onboard processing power. The single board solution is offered as a 52-pin (24.6 mm x 15.7 mm) BGA.

The JP13-LP family concept builds perfect basis for the design of high-sensitive, low-power, compact and cost efficient state-of-the-art GPS enabled system solutions for target platforms such as mobile phones, automotive systems, portable computing devices, and embedded consumer devices. The FALCOM JP13-LP family is also designed to be entire products such as AVL tracking units, handheld GPS.

The core of JP13-LP family units is comprised of the GSC3LP that comes with Digital and RF in a single chip, and the GSW3 software stored into the external FLASH that is API compatible with previous GSW2 software.

The internal GSW3 software completes the package providing flexible system architecture for standalone GPS based products.

Please, consult SiRF (www.sirf.com) for special information about the GSC3LP SiRFstarIII chipset.

Users are advised to proceed quickly to the chapter "Security" and read the hints carefully to secure its optimal use.

1.2 Order options

Before you start up the receiver, make sure that your package includes the following items of the purchased unit. If any item is missing or damaged, please, contact your vendor immediately. According to your requirements you can choose the desired unit.

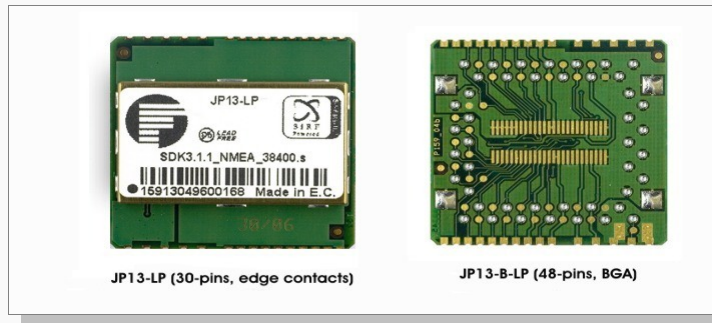

Figure 1: The FALCOM JP13-LP (left) and JP13-B-LP (right) GPS receivers (top and bottom views)

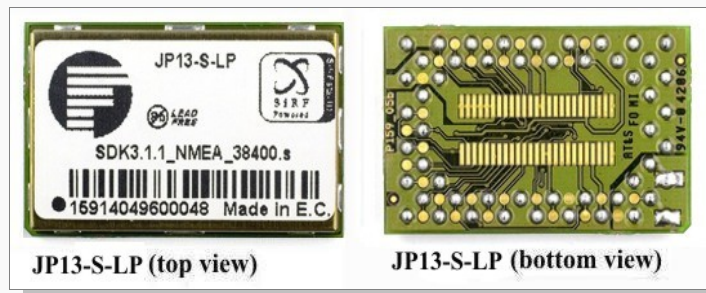

Figure 2: The FALCOM JP13-S-LP version 5b PCB (top and bottom view)

THE TABLE BELOW CONTAINS THE ORDER OPTIONS OF JP13-LP FAMILY.

Name	Options	Description
JP13-LP	Packaged in a 30-pin package (edge contacts)	Pin-compatible to the JP7-T embedded GPS receivers
JP13-B-LP	Packaged in a 48-pin BGA package (available on the bottom side of the unit)	It can be handled like a BGA unit during the surface mounting process.
JP13-S-LP	Packaged in a 52-pin BGA package (available on the bottom side of the unit)	In a very small form factor, it can be handled like a BGA unit during the surface mounting process.
JP13-LP-EV	The Evaluation Kit with mounted JP13-LP or JP13-S-LP GPS receiver.	Evaluation Kit Includes: <ul style="list-style-type: none"> - JP13-LP or JP13-S-LP sample with soldered antenna cable - power supply (AC/DC adapter, Type FW738/05, Output 5VDC 1.3 A) - active GPS antenna (FAL-ANT-3) - RS232 level shifter - RS232 cable to your computer.

Table 1: Ordering options

1.3 Used abbreviations

Abbreviation	Description
BGA	Ball Grid Array
DGPS	Differential GPS
DOP	Dilution of Precision
GPS	Global Positioning System
GGA	GPS Fixed Data
LNA	Low Noise Amplifier
NMEA	National Maritime Electronics Association
PRN	Pseudo - Random Noise Number – The Identity of GPS satellites
RF	Radio Frequency
RP	Receive Protocol
RTC	Real Time Clock
RTCM	Radio Technical Commission for Maritime Services
SDI	Data input
SDO	Data output
SA	Selective Availability
WAAS	Wide Area Augmentation System
MSK	Minimum Shift Keying
PCB	Printed Circuit Board
PRN	Pseudo-random noise
IF	Intermediate Frequency
A/D	Analog/Digital

Table 2: Abbreviations

1.4 Related documents

[1.] SiRF binary and NMEA protocol specification;

www.falcom.de | [Support](#) | [Download](#) | [Documentation](#) | [Sirf](#) | [SiRFmessages_SSIII.zip](#)

[2.] SiRF-demo software and manual;

www.falcom.de | [Support](#) | [Download](#) | [Documentation](#) | [Sirf](#) | [SiRFdemo.pdf](#)

www.falcom.de | [Support](#) | [Download](#) | [Software & Tools](#) | [Sirf](#) | [SiRFdemo.zip](#)

2 SECURITY

This chapter contains important information for the safe and reliable use of the GPS receiver. Please read this chapter carefully before starting to use the GPS receiver.

2.1 General information

The Global Positioning System uses satellite navigation, an entirely new concept in navigation. GPS has become established in many areas, for example, in civil aviation or deep-sea shipping. It is making deep inroads in vehicle manufacturing and before long everyone of us will use it this way or another.

The GPS system is operated by the government of the United States of America, which also has sole responsibility for the accuracy and maintenance of the system. The system is constantly being improved and may entail modifications effecting the accuracy and performance of the GPS equipment.

2.2 Restricted use

Certain restrictions on the use of the GPS receiver may have to be observed on board a plane, in hospitals, public places or government institutions, laboratories etc. Follow these instructions.

2.3 Children

Do not allow children to play with the GPS receiver. It is not a toy and children could hurt themselves or others. The GPS receiver consists of many small parts which can come loose and could be swallowed by small children. Thoughtless handling can damage the GPS receiver.

2.4 Operation/antenna

Operate the GPS receiver with an antenna connected to it and with no obstruction between the receiver and the satellite.

Make absolutely sure that the antenna socket or antenna cable is not shorted as this would render the GPS receiver non-functional.

Do not use the receiver with a damaged antenna. Replace a damaged antenna without delay. Use only a manufacturer-approved antenna. Use only the supplied or an approved antenna with your GPS receiver. Antennas from other manufacturers which are not authorized by the supplier can damage the GPS receiver.

Technical modifications and additions may contravene local radio-frequency emission regulations or invalidate the type approval.

Authorized GPS antennas: **FAL-ANT-3 (active antenna)**

2.5 Electrostatic Discharge (ESD)

The JP13-LP family GPS receiver contains class 1 devices. The following Electrostatic Discharge (ESD) precautions are recommended:

- Protective outer garments.
- Handle device in ESD safeguarded work area.
- Transport device in ESD shielded containers.

- Monitor and test all ESD protection equipment.
- Treat the JP13-LP family GPS receiver as extremely sensitive to ESD.

3 SAFETY STANDARDS

The GPS receiver meets the safety standards for RF receivers and the standards and recommendations for the protection of public exposure to RF electromagnetic energy established by government bodies and professional organizations, such as directives of the European Community, Directorate General V in matters of radio frequency electromagnetic energy.

4 TECHNICAL DATA

4.1 FEATURES

- OEM single board 20 channel GPS receiver
- size:
 - JP13-LP/-B : 25.4 x 25.4 x 3 mm (L x B x H)
 - JP13-S-LP : 24.6 x 15.7 x 3 mm (L x B x H)
- weight:
 - JP13/-B-LP : 3 gr
 - JP13-S-LP : 2 gr
- Casing: Fully shielded
- TCXO ± 0.5 ppm
- FLASH Memory on-chip 8 MBit FLASH and 1 MBit SRAM.
- Operating voltage: +3.3 V DC ± 5 %
- Power consumption: approx. 140 mW (continuous mode)
- Power management : Adaptive TricklePower™ (ATP)
Push-to-Fix (PTF)
For more details see chapter [5.4](#).
- Temperature range: -40 to +85 °C (operation, transportation and storage).
- Protocol: SDI1/ SDO1:
NMEA **38400** baud, Msg.: **GLL, GGA, RMC, GSV, GSA, VTG**.
8 data bits, no parity, 1 stop bit

5 TECHNICAL DESCRIPTION

5.1 Receiver Architecture

The JP13-LP family OEM GPS receiver from FALCOM is a new OEM GPS receiver product that features the SiRFstarIII single chipset. The core of JP13-LP family units is comprised of the GSC3LP that includes the Digital and RF in a single chip. The JP13-LP family is built around a re-configurable high-output segmented matched filter in conjunction with a FFT processor, which can search all 1023 chips of the GPS code simultaneously over a wide frequency range for fast initial acquisition with large uncertainties. The flexibility of the core allows the core processing engine and memory to be reconfigured to track more than 20 satellites using the same hardware. This flexibility makes the JP13-LP family a highly efficient engine for a wide variety of location applications. The core of JP13-LP family contains a built in sequencer, which handles all the high-rate interrupts for GPS and SBAS (WAAS, EGNOS) tracking and acquisitions. After initialization, the receiver handles all the time critical and low latency acquisition, tracking and reacquisition tasks of GPS and SBAS autonomously. The on-chip SRAM size is 1-Mbit (32Kx32) memory that can be used for either instructions or data. The SRAM is designed for a combination of low power and high speed, and can support single cycle reads for all bus speeds.

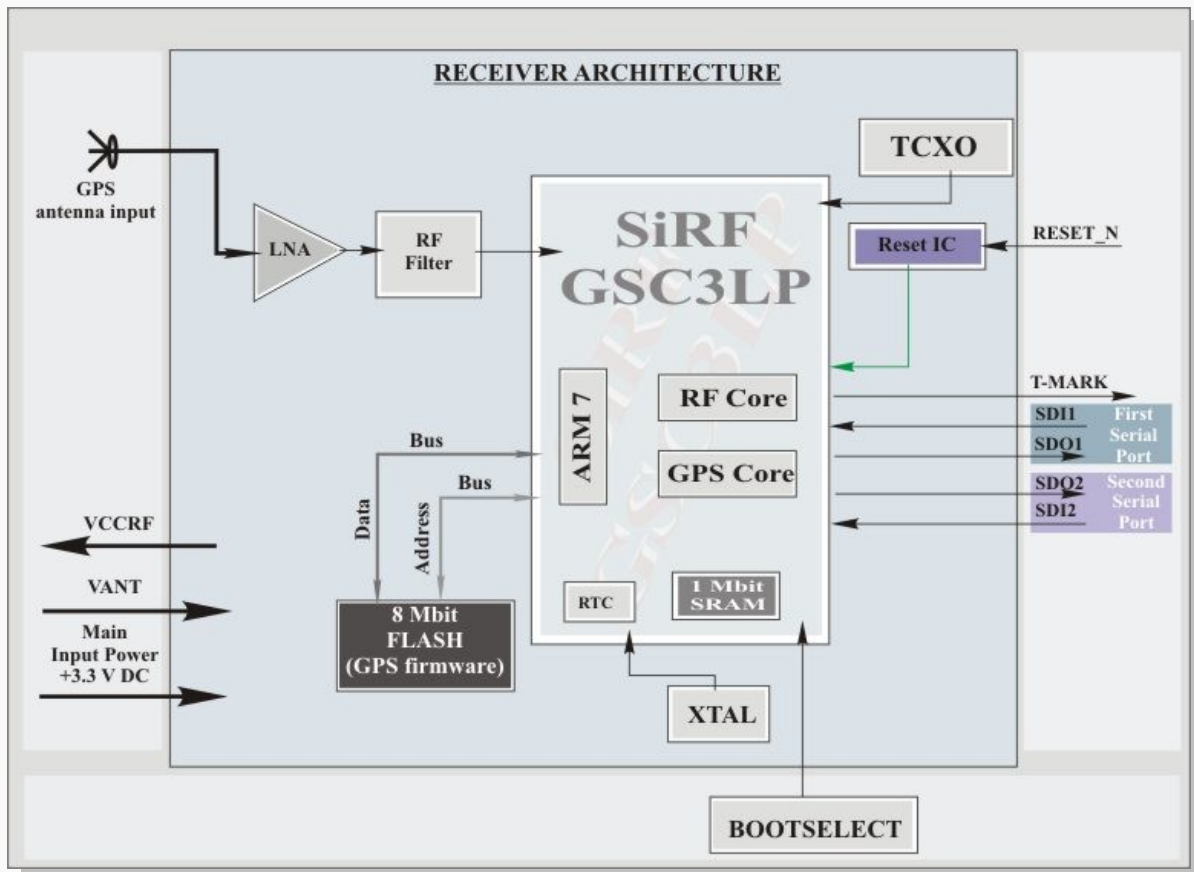

Figure 3: Receiver architecture of the JP13-LP family GPS receiver.

Figure 3 above shows the block diagram of the JP13-LP family architecture.

5.2 Product applications

- *Handheld GPS receiver applications.*
- *Automotive applications.*
- *Marine navigation applications.*
- *Aviation applications.*
- *Timing applications.*

5.3 Technical specifications

5.3.1 Electrical Characteristics

5.3.1.1 *General*

Frequency	L1, 1575.42 MHz
C/A code	1.023 MHz chip rate
Channels	20
Max. update rate	1 Hz
Processor speed	6, 12.5, 25 and 49 MHz
Data bus	16 bit

5.3.1.2 *Accuracy*

Position	Autonomous: 10 meters CEP without SA
SBAS	: < 5 meter
Velocity	0.01 meters/second, without SA
Time	1 microsecond synchronized to GPS time

5.3.1.3 *DGPS Accuracy*

The current GPS operating firmware does not support DGPS.

5.3.1.4 *Datum*

WGS-84

5.3.1.5 *Time to First Position*

GSM	< 20 sec., average
3G	< 20 sec., average
CDMA	< 16 sec., average
Hot start	< 18 sec., average
Hot start (open sky)	< 1 sec., average

Cold start < 42 sec., average

5.3.1.6 Sensitivity*

GSM	15 dBHz**
3G	15 dBHz**
CDMA	15 dBHz**
Tracking	13 dBHz
Hot Start	15 dBHz
Cold Start	30 dBHz

* The sensitivity value is specified at the correlator. On a JP13-LP Evaluation Receiver using GSW3 firmware with the supplied antenna, 17 dBHz is equivalent to -155 dBm. Other board and antenna characteristics will vary.

** Using SiRFLock firmware (not provided by FALCOM).

5.3.1.7 Dynamic Conditions

Altitude	18,000 meters (60,000 feet) max.
Velocity	<515 meters/second (1000 knots) max.
Acceleration	4 g, max.
Jerk	20 meters/second ³ , max.

5.3.1.8 DC Power

Main power	+ 3.3 V DC \pm 5 %
Core power	+1.5 V DC
Continuous mode	approx. 43 mA at 3.3 V DC (with an active antenna "FAL-ANT-3")
Backup battery power	+3 V DC \pm 5%

5.3.1.9 Serial Port

Electrical interface	Two full duplex serial communication, CMOS. <i>Protocol messages:</i> SiRF binary and NMEA-0183 with a baud rate selection. SiRF binary – position, velocity, altitude, status and control NMEA – GGA, GLL, GSA, GSV, RMC, VTG
----------------------	--

5.3.1.10 Time – 1PPS Pulse

Level	CMOS
Pulse duration	100 ms (<i>starting from firmware revision 3.2.4, previous 1.5 μs</i>)
Time reference	At the pulse positive edge

5.4 Power management modes overview

There are three basic operating modes in which the JP13-LP family operates during use. Each mode is used to accomplish a different task during the process of acquiring and maintaining the GPS information. The JP13-LP family include all the functionality necessary to implement the three different modes of operation. By default, the JP13-LP family runs in normal mode (continuous mode). All three different operating modes are described below. Additionally, two of them such as Adaptive TricklePower™ (ATP) and Push-to-Fix (PTF) are designed as power saving modes.

5.4.1 Normal Operation mode

In this default implementation of normal mode the JP13-LP family is fully powered and performs the function of signal search, acquisition, measurement and satellite tracking. The amount of time spent in the initial full power is dependent on the start conditions such as the number of satellites for which the ephemeris data must be collected and the time to calibrate the RTC. When the JP13-LP family has been locked-on to at least four satellites, the receiver is able to calculate its current positions. In this mode the JP13-LP family is fully powered and satellite searching, initial acquisition, initial position calculation and tracking measurement functions are always performed. In order to reduce the start up time of the receiver it is preferable to connect externally a backup battery, so that the RTC is running during the power interrupt. The backup power is required for retention of SRAM memory and maintaining the Real-Time-Clock. The validity of data stored in SRAM is kept due to RTC keeps running and these data will be needed on the next power up scenario.

5.4.2 Adaptive TricklePower mode (ATP)

Adaptive TricklePower (ATP) is a variant of TricklePower™. But only ATP and Push-To-Fix (PTF is described in next chapter) modes are supported on JP13-LP family. ATP is best suited for applications where regular updates are required, and where stronger signal levels are expected. The transition of receiver into the ATP mode can be done and configured by using either the **Action|Set Low Power (Trickle Power) ...** command available in SiRFDemo evaluation software or the input command described in chapter 5.4.4 on page 18.

When ATP is enabled the receiver will maximize the navigation performance. Depending on different states of the power management circuits, the receiver belongs to one of three system states:

Full Power State (Acquisition/Tracking modes)

After initial turn on or system reset, the JP13-LP will remain in the full power state until a series of Kalman filter navigation solution is obtained, all ephemeris data is collected and the RTC is calibrated before transitioning to CPU-state. The receiver stays in full power state until a position solution is made and estimated to be reliable. In this state all RF circuitry and the baseband are fully powered. Even in this state, there is a difference in power consumption during acquisition mode and tracking mode. During the acquisition mode, processing is more intense, thus consuming more power (Diagram is shown below that is simplified for ease of understanding. Timing values are only examples).

CPU-State

In this state the LNA in the RF section is shut off. The TCXO and fractional synthesizer from the RF section are still powered in order to provide a clock to the CPU. This state

is entered when the satellite measurements have been collected but the navigation solution still needs to be computed, thus consuming power is less than in the full power state.

Standby state

In the standby state, power remains applied to the JP13-LP family, but the RF section is completely powered off and the clock to the baseband is stopped. About 900 μ A of current is drawn in this state for the internal core regulator, RTC and battery-backed RAM. The receiver enters this state when a position fix has been computed and reported. Typically, before shutting down the RTC wakeup register is programmed to wake up the system sometime in the future.

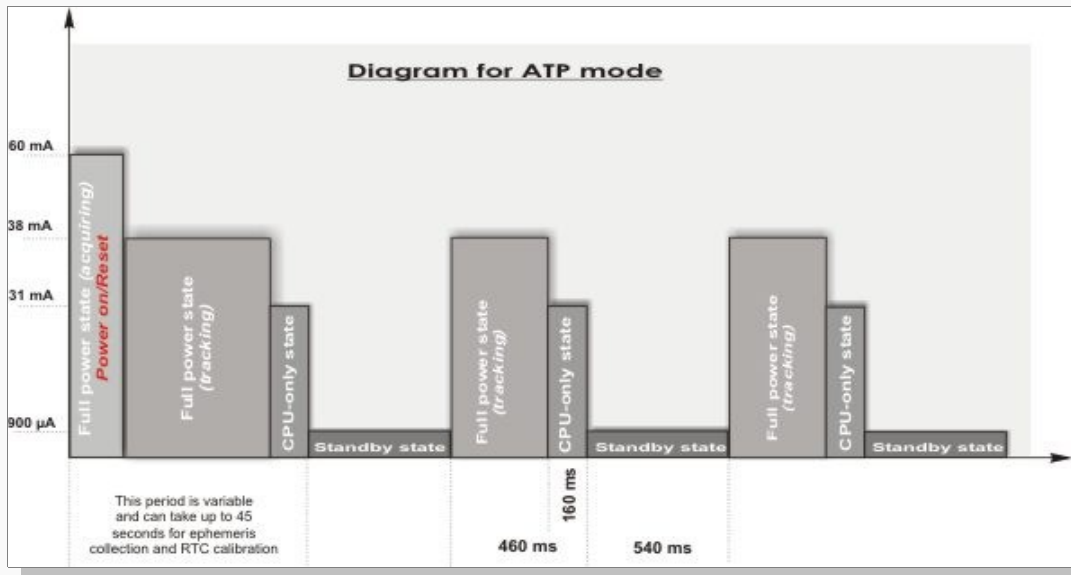

Remark: The environment temperature may also affect the power consumption in the Standby state.

Figure 4: Three system states into the ATP mode.

The transition from Standby state back to the full power is generated through the internal RTC, which transmits a wake up signal to the GPS engine to switch it on. The JP13-LP is woken up and begins to acquire the on view satellites and to collect their data. Under normal tracking conditions, the receiver is set for a specific update period (range from 1 to 10 seconds), and a specific sampling time during each period (range from 200 to 900 ms). The receiver turns to full power state for the sampling time to collect data, and then operates in Standby state for the remainder of the update period. The next full-power state is initiated by an RTC wakeup. But in harsh tracking environments the receiver automatically switches to full power state to improve navigation performance. When the satellites are sorted according to their signal strength, the fourth satellite determines if the transition will occur or not. The threshold is 26 dB-Hz. When tracking, conditions return to normal (four or more satellites with C/No of 30 dB-Hz or higher), the receiver switches back to the power saving mode.

5.4.3 Push-to-Fix Mode

The Push-to-Fix mode puts the FALCOM JP13-LP family into a background duty cycle which provides a periodic refresh of position, receiver time, ephemeris data and RTC calibration every 10 seconds to 2 hours. The transition of receiver into the Push-to-Fix mode can be implemented and configured by using either the **Action | Set Low Power (Trickle Power)** ... command available in SiRFDemo evaluation software or the input command described in chapter 5.4.4 on page 18.

The PTF period is 30 minutes by default but can be anywhere between 10 seconds and 2 hours. When the PTF mode is enabled, due to a new PTF cycle, the receiver will stay on full power until the good navigation solution is computed. The so-called hibernate state will follow for the remainder of the period. For example, if the receiver took 15 seconds to fix position and refresh ephemeris on the default period of 30 minutes, the receiver will sleep for the 29 minutes and 45 seconds. Whenever the receiver wakes up, it collects almanac and ephemeris data and then goes back to the previous sleep phase again.

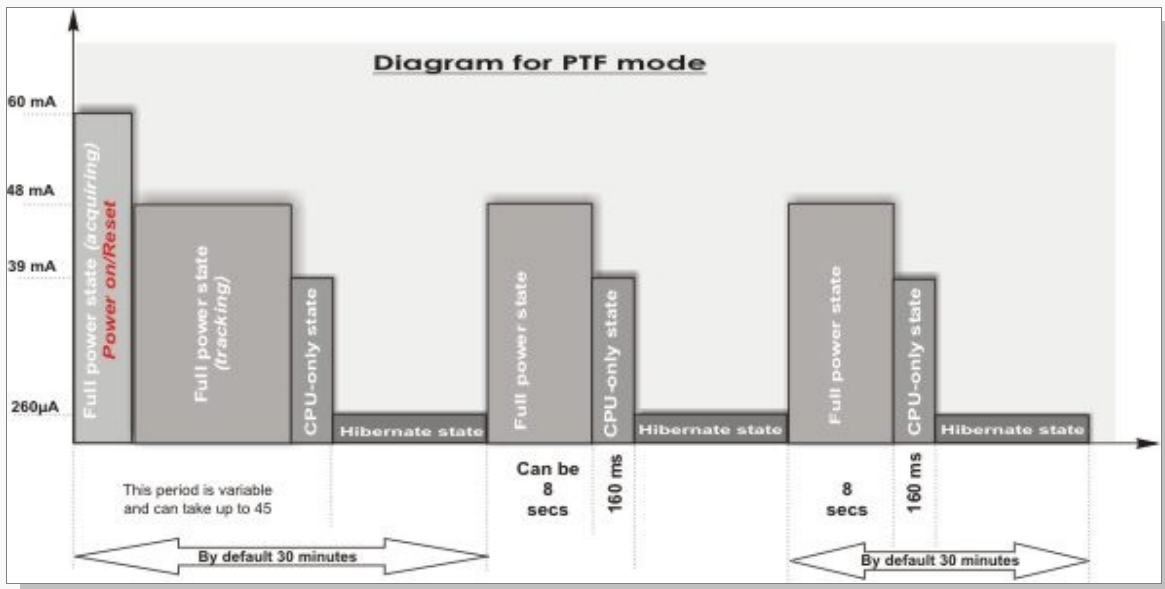

Remark: The environment temperature may also affect the power consumption in the Hibernate state.

Figure 5: Three system states into the PTF mode.

5.4.4 NMEA input message for ATP & PTF Mode

Power saving mode is disabled by default. In order to enable it, input the NMEA message in table below. The description of each parameter used for Adaptive TricklePower or Push-to-Fix™ is listed below. How to send these messages to the target unit, refer to chapter **Appendix** section 11.1 page 37.

Syntax	\$PSRF107,<Mode>,<OnTimeMs*>,<LPInterval*>,<MaxAcqTimeMs>,<MaxOffTimeMs>,<TPAdaptive>*21<CR><LF>
Examples	\$PSRF107,1,400,2000,60000,60000,1*17<CR><LF> \$PSRF107,2,400,60000,60000,60000,0*21<CR><LF> \$PSRF107,0,0,0,0,0,0*21<CR><LF>

Parameter Description

<Mode>

It defines the mode to be performed. It can be set to:

- 0** Sets the target receiver back to the Continuous mode (full power).
- 1** Sets the target receiver into the Adaptive TricklePower (TP) mode.
- 2** Sets the target receiver into the Push-To-Fix (PTF) mode.

<OnTimeMs*>

It defines the OnTime period in milliseconds the receiver will stay in full power state until a position solution is made and estimated to be reliable. Please note that, in harsh tracking environments the receiver automatically switches to full power state to improve navigation performance even if the defined OnTime has been expired. When the satellites are sorted according their signal strength, the fourth satellite determines if the transition to Standby mode/hibernate state will occur or not. It can be set to a value between:

- 200 ... 900** OnTime period in milliseconds

<LPInterval*>

It defines the complete interval of time in milliseconds the receiver will stay in full power and Standby mode/hibernate state.

It can be set to a value between:

- 1000 ... 10000** The interval of time in milliseconds intended for Adaptive TricklePower (ATP) mode.
- 10000 ... 7200000** The interval of time in milliseconds intended for Push-To-Fix (PTF) mode.

<MaxAcqTimeMs>

It specifies the Maximum Acquire Time in milliseconds how long the target receiver should attempt to acquire satellites and navigate. If this time elapses and no GPS-fix is obtained, the target receiver is set into the sleep mode for up to *MaxOffTime* in ms. It means, the target receiver searches for *MaxAcqTime* in ms, sleeps for *MaxOffTime* in ms, searches again for *MaxAcqTime* in ms, etc. It can be set to a value between:

- 1000 ... No Limit**

<MaxOffTimeMs>

It specifies the Maximum Off Time in milliseconds how long the target receiver should remain off (sleep mode) before making another attempt to navigate. This mode is enabled, if the target receiver is turned on and acquires satellites, but does not navigate. This mode is disabled, if the target receiver is turned on, acquires and navigates. It can be set to a value between:

- 1000 .. 1800000**

<TPAdaptive>

It enables/disables the Adaptive TricklePower (ATP) mode if the value of the <Mode> parameter is set to **1**, otherwise it does not have any effect. It can be set to:

- 0** It disables the Adaptive TricklePower (ATP) mode.

1 It enables the Adaptive TricklePower (ATP) mode.

<*CS>

CHECKSUM is a two-hex character as defined in the NMEA specification. Use of checksums is required on all input messages. For more detailed information, refer to the chapter [7.2.3](#) page [29](#).

<CR><LF>

Each message is terminated using Carriage Return (CR) Line Feed (LF) which is hex 0D 0A. Because 0D 0A are not printable ASCII characters, they are omitted from the example strings, but must be sent to terminate the message and cause the receiver to process that input message.

*** Note:**

- *SiRF recommends the use of 300 ms, 1-second or 400 ms, 2-second for optimum performance.*

6 HARDWARE INTERFACE AND CONFIGURATION SIGNALS

⚡ Please note that, the black point on the bottom-left corner marks the antenna side and not Pin1 (see figure 6).

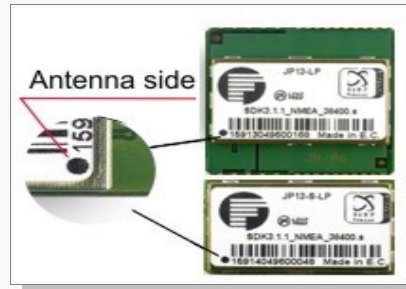

Figure 6: JP13-LP & JP13-S-LP orientation point for antenna site.

6.1 Interfaces (pin-out) of the JP13-LP

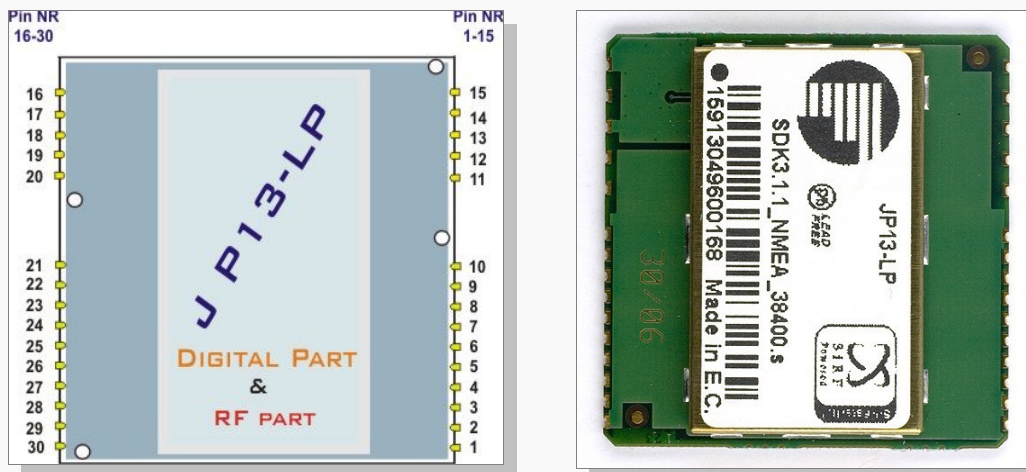

Figure 7: JP13-LP pin out.

Pin	Name	I/O	Description	Level
1	VCC	I	Main power supply. It also powers the RTC and SRAM.	VI = + 3.3 ±5%
2	GND	-	Digital ground	GND (0 V)
3	BOOT_SELECT	I	Boots in update mode, if high	CMOS
4	SDI1	I	Serial Data Input A (first receive line).	CMOS 3.3 V DC level
5	SDO1	O	Serial Data Output A (first transmit line).	CMOS 3.3 V DC level
6	SDO2	O	Serial Data Output B (second transmit line).	CMOS 3.3 V DC level
7	SDI2	I	Serial Data Input B (second receive line).	CMOS 3.3 V DC level
8	SPI_EN	I	Control output for internal use, only. Do not use, leave it open.	-
9	VCCGSP3	O	Control output for internal use, only. Do not use, leave it open.	-
10	GND	-	Digital ground	GND (0 V)
11	RF_GND	-	Analog grounds	GND (0 V)
12	RF_GND	-	Analog grounds	GND (0 V)
13	RF_GND	-	Analog grounds	GND (0 V)
14	RF_GND	-	Analog grounds	GND (0 V)
15	RF_GND	-	Analog grounds	GND (0 V)

This confidential document is the property of FALCOM and may not be copied or circulated without permission.

Pin	Name	I/O	Description	Level
16	RF_GND	-	Analog grounds	GND (0 V)
17	RF_IN	I	GPS signal from connected antenna	50 Ohms @ 1.575 GHz
18	RF_GND	-	Analog ground	GND (0 V)
19	V_ANT	I	Power supply for active antenna	upto +12 V DC
20	VCCRF	O	Supply voltage of RF section	+ 2.85 V DC / max. 25 mA
21	V_BAT	I	Power for RTC and SRAM. Starting form the JP13-LP_REV04A PCB version the Vbat signal incorporates voltage detection.	+3 V DC ±5%
22	RESET_N	I	Resets the GPS unit when it is driven LOW.	LOW = 0 V (GND)
23	VCC/GPIO10	I	Main power supply. It also powers the RTC and SRAM.	VI = + 3.3 ±5%
24	SPI_DATA	O	Control output for internal use, only. Do not use, leave it open.	-
25	NADC_D	I	Control output for internal use, only. Do not use, leave it open.	-
26	SPI_CLK	I	Control output for internal use, only. Do not use, leave it open.	-
27	GPIO0	I/O	General purpose input/output	CMOS
28	Odometer/ GPIO1	I/O	Alternate function is Odometer interface for SiRFDRive (GSW3-version). Internal pull-down resistor. Default input at reset. Do not use, leave it open.	CMOS
29	T-MARK	O	One pulse per second	CMOS
30	GND	-	Digital ground	GND (0 V)

Table 3: Pin assignment of the JP13-LP

6.2 Interfaces (ball assignment) of the JP13-B-LP

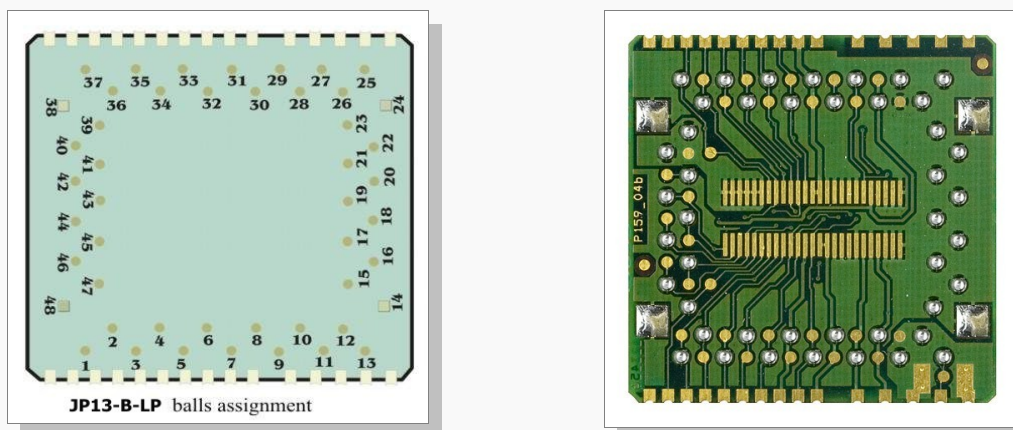

Figure 8: JP13-B-LP ball assignment.

The left figure shows the ball assignments.

Ball	Name	I/O	Description	Level
1	Odometer/ GPIO1	I/O	Alternate function is Odometer interface for SiRFDRive (GSW3-version). Internal pull-down resistor. Default input at reset. Do not use, leave it open.	CMOS
2	GPIO0	I/O	General propose input/output	CMOS
3	SPI_CLK	I	Control output for internal use, only. Do not use, leave it open.	-
4	NADC_D	I	Control output for internal use, only. Do not use, leave it open.	-
5	SPI_DATA	O	Control output for internal use, only. Do not use, leave it open.	-
6	VCC/GPIO10	I	Main power supply. It also powers the RTC and SRAM.	VI = + 3.3 ±5%
7	RESET_N	I	Resets the GPS unit when it is driven LOW.	LOW = 0 V (GND)
8	V_BAT	I	Power for RTC and SRAM. Power for RTC and SRAM. Starting form the JP13-LP_REV04A PCB version the Vbat signal incorporates voltage detection.	+3 V DC ±5%
9	VCCRF	O	Supply voltage of RF section	+ 2.85 V DC / max. 25 mA

Ball	Name	I/O	Description	Level
10	V_ANT	I	Power supply for an active antenna	Up to +12 V DC / max. 25 mA
11	RF_GND	-	Analog ground	GND (0 V)
12	RF_GND	-	Analog ground	GND (0 V)
13	RF_IN	I	GPS signal from connected antenna	50 Ohms @ 1.575 GHz
14	GND	-	Digital ground	GND (0 V)
15	GND	-	Digital ground	GND (0 V)
16	GND	-	Digital ground	GND (0 V)
17	GND	-	Digital ground	GND (0 V)
18	GND	-	Digital ground	GND (0 V)
19	GND	-	Digital ground	GND (0 V)
20	GND	-	Digital ground	GND (0 V)
21	GND	-	Digital ground	GND (0 V)
22	GND	-	Digital ground	GND (0 V)
23	GND	-	Digital ground	GND (0 V)
24	GND	-	Digital ground	GND (0 V)
25	GND	-	Digital ground	GND (0 V)
26	GND	-	Digital ground	GND (0 V)
27	GND	-	Digital ground	GND (0 V)
28	VDDK*	O	Control output for internal use, only. Do not use, leave it open.	-
29	ON/OFF*	I	Control output for internal use, only. Do not use, leave it open.	-
30	GND	-	Digital Ground	GND (0 V)
31	VCCGSP3	O	Control output for internal use, only. Do not use, leave it open.	-
32	SPI_EN	I	Control output for internal use, only. Do not use, leave it open.	-
33	SDI2	I	Serial Data Input B (second receive line).	CMOS 3.3 V DC level
34	SDO2	O	Serial Data Output B (second transmit line).	CMOS 3.3 V DC level
35	SDO1	O	Serial Data Output A (first transmit line).	CMOS 3.3 V DC level
36	SDI1	I	Serial Data Input A (first receive line).	CMOS 3.3 V DC level
37	BOOT_SELECT	I	Boots in update mode, if high	CMOS
38	GND	-	Digital ground	GND (0 V)
39	VCC	I	Main power supply. It also powers the RTC and SRAM.	VI = + 3.3 ±5%
40	VCC	I	Main power supply. It also powers the RTC and SRAM.	VI = + 3.3 ±5%
41	GND	-	Digital Ground	GND (0 V)
42	Wakeup	O	Control output for internal use, only. Do not use, leave it open.	-
43	PWRCTL	O	Control output for internal use, only. Do not use, leave it open.	-
44	Timer_sync	O	Control output for internal use, only. Do not use, leave it open.	-
45	CS2	O	Control output for internal use, only. Do not use, leave it open.	-
46	NADC_CS	O	Control output for internal use, only. Do not use, leave it open.	-
47	T-MARK	O	1 PPS Time Mark Output	CMOS
48	GND	-	Digital ground	GND (0 V)

* The main difference between the JP13-B-LP and the JP17-TB is the function of pins 28 and 29.

Table 4: Pin assignment of the JP13-B-LP

6.3 Interfaces (balls assignment) of the JP13-S-LP

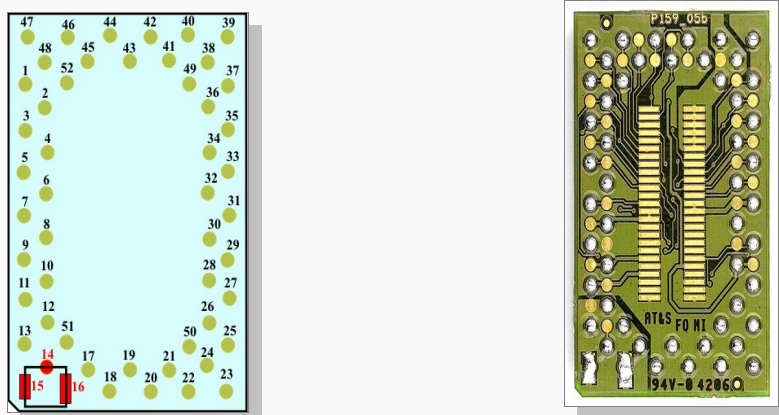

Figure 9: JP13-S-LP ball assignment.

Ball	Name	I/O	Description	Level
1	Odometer/ GPIO1	I/O	Alternate function is Odometer interface for SiRFDRive (GSW3-version). Internal pull-down resistor. Default input at reset. Do not use, leave it open.	CMOS
2	GPIO0	I/O	General propose input/output.	CMOS
3	SPI_CLK	I	Control output for internal use, only. Do not use, leave it open.	-
4	NADC_D	I	Control output for internal use, only. Do not use, leave it open.	-
5	SPI_DATA	O	Control output for internal use, only. Do not use, leave it open.	-
6	NC	-	Not connected	-
7	RESET_N	I	Resets the GPS unit when it is driven LOW.	LOW = 0 V (GND)
8	V_BAT	I	Power for RTC and SRAM	+3 V DC \pm 5%
9	GND	-	Digital ground	GND (0 V)
10	VCCRF	O	Supply voltage of RF section	+ 2.85 V DC / I _{max} . 25 mA
11	V_ANT	I	Power supply for an active antenna	Up to +12 V DC / I _{max} . 25 mA
12	RF_GND	-	Analog ground	GND (0 V)
13	RF_GND	-	Analog ground	GND (0 V)
14	RF_IN	I	GPS signal from connected antenna	50 Ohms @ 1.575 GHz
15	RF_GND	-	Analog ground	GND (0 V)
16	RF_GND	-	Analog ground	GND (0 V)
17	RF_GND	-	Analog ground	GND (0 V)
18	GND	-	Digital ground	GND (0 V)
19	GND	-	Digital ground	GND (0 V)
20	GND	-	Digital ground	GND (0 V)
21	GND	-	Digital ground	GND (0 V)
22	GND	-	Digital ground	GND (0 V)
23	NC	-	Not connected	-
24	NC	-	Not connected	-
25	NC	-	Not connected	-
26	NC	-	Not connected	-
27	NC	-	Not connected	-
28	VDDK	O	Control output for internal use, only. Do not use, leave it open.	-
29	ON/OFF	I	Control output for internal use, only. Do not use, leave it open.	-
30	GND	-	Digital ground	GND (0 V)
31	VCCGSP3	O	Control output for internal use, only. Do not use, leave it open.	-
32	SPI_EN	I	Control output for internal use, only. Do not use, leave it open.	-
33	SDI2	I	Serial Data Input B (second receive line).	CMOS 3.3 V DC level
34	SDO2	O	Serial Data Output B (second transmit line).	CMOS 3.3 V DC level

This confidential document is the property of FALCOM and may not be copied or circulated without permission.

Ball	Name	I/O	Description	Level
35	SDO1	O	Serial Data Output A (first transmit line).	CMOS 3.3 V DC level
36	SDI1	I	Serial Data Input A (first receive line).	CMOS 3.3 V DC level
37	BOOT_SELECT	I	Boots in update mode, if high	CMOS
38	VCC	I	Main power supply. It also powers the RTC and SRAM.	VI = + 3.3 ±5%
39	GND	-	Digital ground	
40	VCC	I	Main power supply. It also powers the RTC and SRAM.	VI = + 3.3 ±5%
41	GND	-	Digital ground	GND (0 V)
42	Wakeup	O	Control output for internal use, only. Do not use, leave it open.	-
43	PWRCTL	O	Control output for internal use, only. Do not use, leave it open.	-
44	Timer_sync	O	Control output for internal use, only. Do not use, leave it open.	-
45	CS2	O	Control output for internal use, only. Do not use, leave it open.	-
46	NADC_CS	O	Control output for internal use, only. Do not use, leave it open.	-
47	GND	O	Digital ground	GND (0 V)
48	T-MARK	O	1 PPS Time Mark Output	CMOS
49	VCC	I	Main power supply. It also powers the RTC and SRAM.	VI = + 3.3 ±5%
50	NC	-	Not connected	-
51	RF_GND	-	Analog ground	GND (0 V)
52	GND	-	Digital ground	GND (0 V)

Table 5: Pin assignment of the JP13-S-LP

6.4 Configuration and timing signals

- RESET_N** *This pin provides an active-low (GND) reset input to the board. It causes the board to reset and to start searching for satellites. If not utilized, this input pin may be left open.*
- T-MARK** *This pin provides 1 pulse per second output from the board, which is synchronized to within 1 microsecond of GPS time. The output is a CMOS level signal.*
- BOOT_SELECT** *Set this Pin to high (+3.3 V DC) for reprogramming the flash of the JP13-LP family (for instance updating a new firmware for the JP13-LP).*
- SDI1** *This is the main receiving channel and is used to receive software commands to the board from SiRFdemo software or from user written software.*
- SDI2** *This is the auxiliary receiving channel used to input differential corrections to the board to enable DGPS navigation. **Note that, the current operating firmware does not support DGPS.***
- SDO1** *This is the main transmitting channel and is used to output navigation and measurement data to SiRFdemo or user written software.*
- SDO2** *For user's application.*
- VCC** *This is the main DC power supply for 3,3 V ±5 % powered board JP13-LP family.*
- RF_IN** *Active antennas have an integrated low-noise amplifier. They can be directly connected to this pin (**RF_IN**). If an active antenna is connected to **RF_IN**, the integrated low-noise amplifier of the antenna needs to be supplied with the correct voltage through pin **V_ANT**.*

Caution: Do not connect or disconnect the antenna while the JP13-LP family is running.

V_ANT

Caution: The RF_IN is always fed from the input voltage on the V_ANT. Do not use any input voltage on this pin.

This pin is an input and reserved for an external DC power supply for an active antenna.

The antenna bias for an external active antenna can be provided in two ways to pin **V_ANT**.

In order to use a 5 V or 12 V active GPS antenna, the **V_ANT** has to be connected to 5 V, 12 V external power supply, respectively.

The other possibility is available when you connect the **VCCRF** output (which provides 2.85 V) to **V_ANT**, so that an antenna with 2.85 V supply voltage can be used.

Hint: The input voltage on the **V_ANT** should be chosen in according to the antenna to be used.

Note: The GPS receiver JP13-LP family has to be connected to an active GPS antenna with a max. current 25 mA.

VCCRF

This pin is an output, which provides **+2.85 V DC**, and can be connected to the **V_ANT**, to supply the connected GPS antenna (2,85V active antenna).

7 SOFTWARE INTERFACE

The FALCOM JP13-LP family supports NMEA-0183 and SiRF binary protocols. A short description of these protocols is provided herein.

For more detailed information about the messages listed in tables below, please refer to the SiRFstarIII message set specification available in the section “Support/Downloads/Documentation/SiRF/SiRFmessages_SSIII.zip” at FALCOM homepage.

7.1 SiRF binary data message

Table 6 lists the messages for the SiRF output

Hex	ASCII	Name	Description
0 x 02	2	Measured Navigation Data	Position, velocity and time
0 x 03	3	True Tracker Data	Not implemented
0 x 04	4	Measured Tracking Data	Satellite and C/No information
0 x 06	6	SW Version	Receiver software
0 x 07	7	Clock Status	Current clock status
0 x 08	8	50 BPS Subframe Data	Standard ICD format
0 x 09	9	Throughput	Navigation complete data
0 x 0A	10	Error ID	Error coding for message failure
0 x 0B	11	Command Acknowledgement	Successful request
0 x 0C	12	Command No Acknowledgement	Unsuccessful request
0 x 0D	13	Visible List	Auto Output
0 x 0E	14	Almanac Data	Response to Poll
0 x 0F	15	Ephemeris Data	Response to Poll
0 x 10	16	Test Mode 1	For use with SiRFtest (Test Mode 1)
0 x 12	18	Ok To Send	CPU ON/OFF (Trickle Power)
0 x 13	19	Navigation Parameters	Response to Poll
0 x 14	20	Test Mode 2	Additional test data (Test Mode 2)
0 x 1C	28	Nav. Lib. Measurement Data	Measurement Data
0 x 1E	30	Nav. Lib. SV State Data	Satellite State Data
0 x 1F	31	Nav. Lib. Initialization Data	Initialization Data
0 x FF	255	Development Data	Various status messages

Table 6: SiRF Output Messages

Table 7 lists the message list for the SiRF input messages.

Hex	ASCII	Name	Description
0 x 55	85	Transmit Serial Message	User definable message
0 x 80	128	Initialize Data Source	Receiver initialization and associated parameters
0 x 81	129	Switch to NMEA Protocol	Enable NMEA message, output rate and baud rate
0 x 82	130	Set Almanac (upload)	Sends an existing almanac file to the receiver
0 x 84	132	Software Version (Poll)	Polls for the loaded software version
0 x 86	134	Set Main Serial Port	Baud rate, data bits, stop bits and parity
0 x 87	135	Switch Protocol	Obsolete
0 x 88	136	Mode Control	Navigation mode configuration
0 x 89	137	DOP Mask Control	DOP mask selection and parameters
0 x 8B	139	Elevation Mask	Elevation tracking and navigation masks
0 x 8C	140	Power Mask	Power tracking and navigation masks
0 x 8D	141	Editing Residual	Not implemented
0 x 8E	142	Steady-State Detection – not used	Not implemented
0 x 8F	143	Static Navigation	Configuration for static operation
0 x 90	144	Poll Clock Status (Poll)	Polls the clock status
0 x 92	146	Poll Almanac	Polls for almanac data

0 x 93	147	Poll Ephemeris	Polls for ephemeris data
0 x 94	148	Flash Update	On the fly software update
0 x 95	149	Set Ephemeris (upload)	Sends an existing ephemeris to the receiver
0 x 96	150	Switch Operating Mode	Test mode selection, SV ID and period
0 x 97	151	Set Trickle Power Parameters	Push to fix mode, duty cycle and on time
0 x 98	152	Poll Navigation Parameters	Polls for the current navigation parameters
0 x A5	165	Set UART Configuration	Protocol selection, baud rate, data bits, stop bits and parity
0 x A6	166	Set Message Rate	SiRF binary message output rate
0 x A7	167	Low Power Acquisition Parameters	Low power configuration parameters
0 x B6	182	Set UART Configuration	Obsolete

Table 7: SiRF Input Messages

7.2 NMEA data message

7.2.1 NMEA output messages

Table 7 lists all NMEA output messages supported by SiRFstarIII evaluation receiver and a brief description.

Option	Description
GGA	Time, position and fix type data.
GLL	Latitude, longitude, UTC time of position fix and status.
GSA	GPS receiver operating mode, satellites used in the position solution and DOP values.
GSV	The number of GPS satellites in view satellite ID numbers, elevation, azimuth and SNR values.
MSS	(This message can be switched on via SiRFdemo software) Signal-to-noise ratio, signal strength, frequency and bit rate from a radio-beacon receiver.
RMC	Time, date, position, course and speed data.
VTG	Course and speed information relative to the ground.

Table 8: NMEA Output Messages

7.2.2 NMEA input messages

Message	MID ¹	Description
Set Serial Port	100	Set PORT A parameters and protocol
Navigation Initialization	101	Parameters required for start using X/Y/Z ²
Query/Rate Control	103	Query standard NMEA message and/or set output rate
LLA Navigation Initialization	104	Parameters required for start using Lat/Lon/Alt ³
Development Data On/Off	105	Development Data messages On/Off
MSK Receiver Interface	MSK	Command message to a MSK radio-beacon receiver.

Table 9: NMEA Input Messages

1. Message Identification (MID).
2. Input co-ordinates must be WGS84.
3. Input co-ordinates must be WGS84.

Note: NMEA input messages 100 to 105 are SiRF proprietary. The MSK NMEA string is as defined by the NMEA 0183 standard.

7.2.3 Transport Message

Start Sequence	Payload	Checksum	End Sequence
\$PSRF<MID> ¹	Data ²	*CKSUM ³	<CR> <LF> ⁴

1. Message Identifier consisting of three numeric characters. Input messages begin at MID 100.
2. Message specific data. Refer to a specific message section for <data>...<data> definition.
3. CHECKSUM is a two-hex character checksum as defined in the NMEA specification. Use of checksums is required on all input messages.
4. Each message is terminated using Carriage Return (CR) Line Feed (LF) which is \r\n which is hex 0D 0A. Because \r\n are not printable ASCII characters, they are omitted from the example strings, but must be sent to terminate the message and cause the receiver to process that input message.

Checksum

The checksum is 15-bit checksum of the bytes in the payload data. The following pseudo code defines the algorithm used.

Let *message* to be the array of bytes to be sent by the transport.

Let *msgLen* be the number of bytes in the message array to be transmitted.

Clearly to say, the string over which the checksum has to be calculated is between the "\$" and "*" (without characters "\$" and "*").

Index = first

checksum = 0

while index < msgLen

checksum = checksum + message[index]

checksum = checksum AND (2¹⁵-1).

Note: All fields in all proprietary NMEA messages are required, none are optional. All NMEA messages are comma delimited.

8 MECHANICAL DRAW

The following chapters describe the mechanical dimensions of JP13-LP family and give recommendations for integrating of the JP13-LP family into your application platform. Note that, the absolute maximum dimension for JP13-LP and JP13-B-LP modules is: 25.4 mm x 25.4 mm (L x B).

Figures 10 and 11 show the top view on JP13-LP and JP13-S-LP GPS receivers and provide an overview of the mechanical dimensions of the board, respectively.

Please note that, the JP13-LP receiver and all its members have a dimension tolerance: ± 0.1 mm.

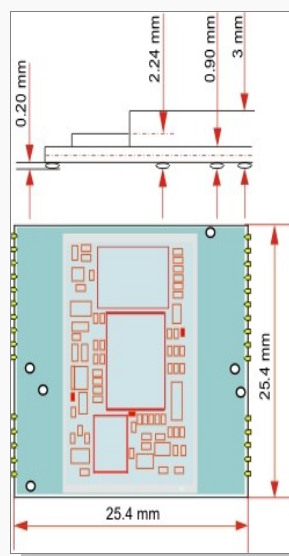

Figure 10: The mechanical draw of the JP13-LP with edge contacts

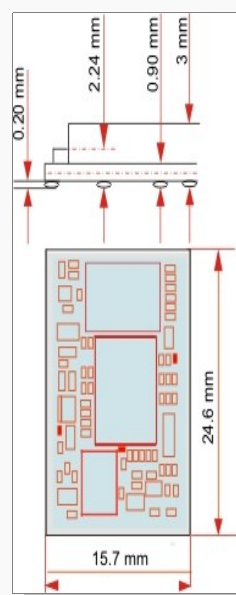

Figure 11: The mechanical draw of the JP13-S-LP receiver

Figure 12 shows the bottom view on JP13-B-LP and provides an overview of the mechanical dimensions of the pointed balls. The diameter of the test points is **0.80 mm**. The test points are not represented in the figure below. See **Figure 8** above as reference.

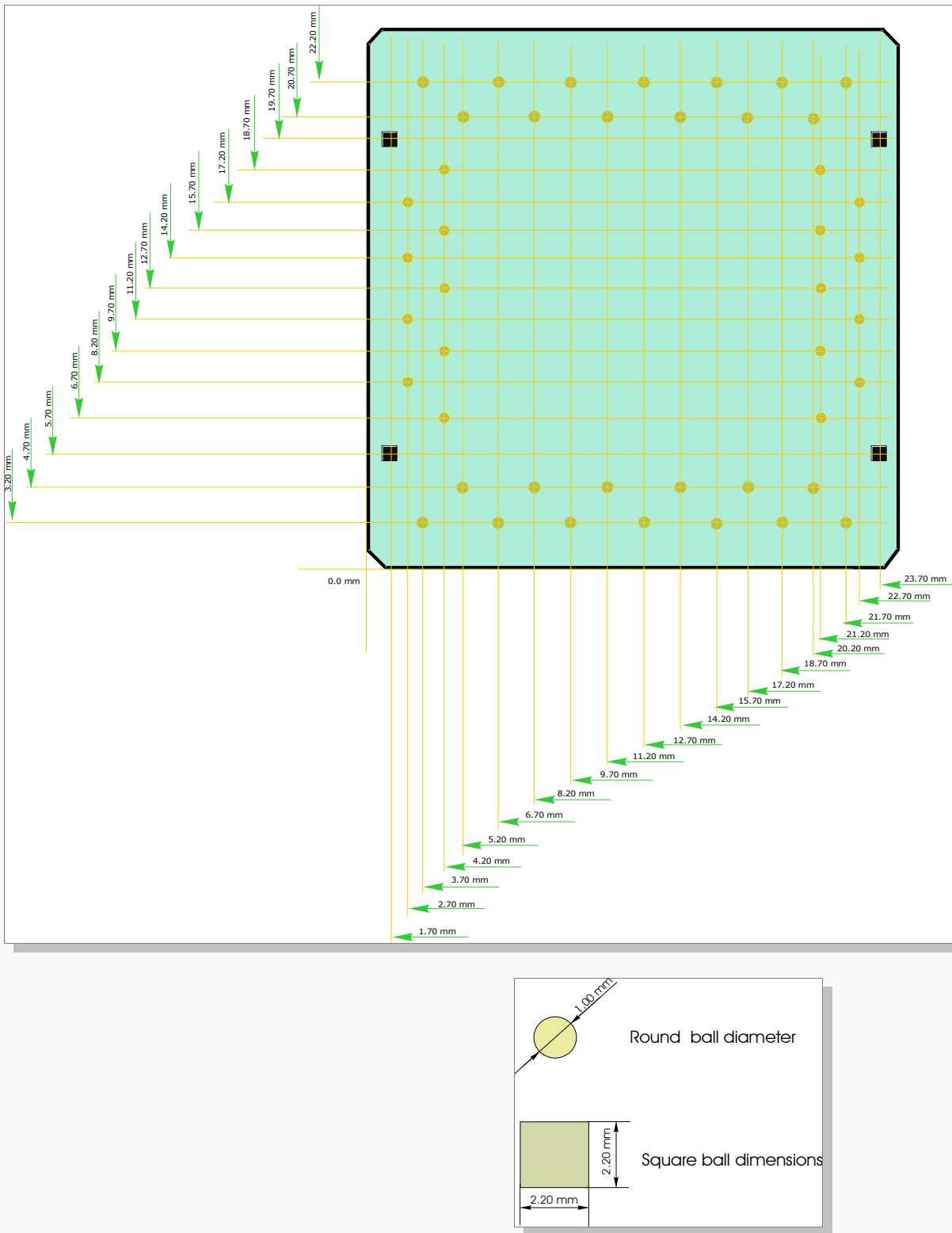

Figure 12: The mechanical draw of the JP13-B-LP receiver

This confidential document is the property of FALCOM and may not be copied or circulated without permission.

Figure 13 shows the bottom view on JP13-S-LP and provides an overview of the mechanical dimensions of the pointed balls.

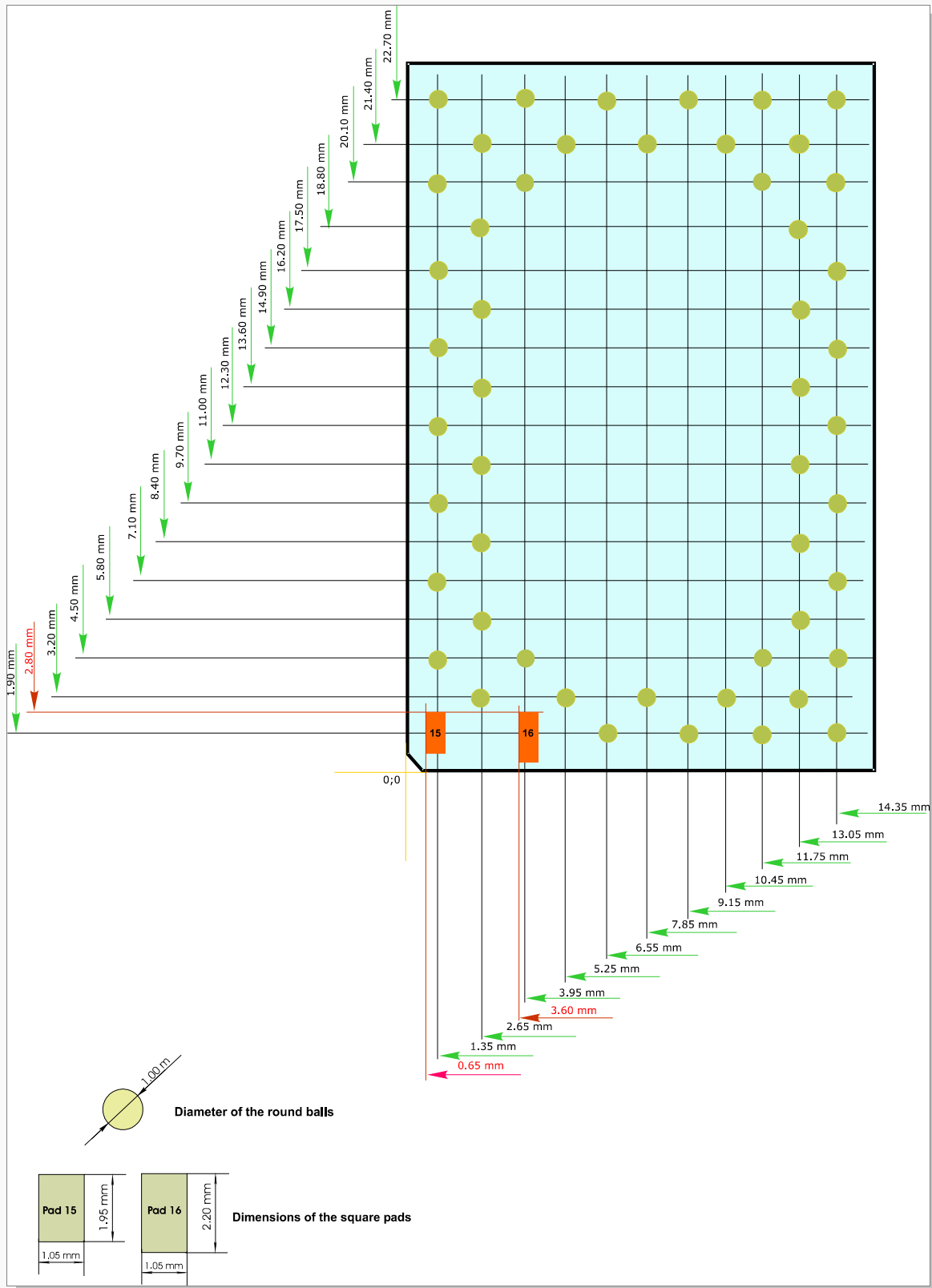

Figure 14: The mechanical draw of the JP13-S-LP receiver

This confidential document is the property of FALCOM and may not be copied or circulated without permission.

9 LAYOUT RECOMMENDATION

9.1 Ground planes

JP13-LP GPS receiver needs two different ground planes. The pins RF_GND shall be connected to analog ground, the pins GND to digital ground, see tables 3, 4 and Table 5.

The two ground planes shall be separated:

- ◆ planes are connected inside the receiver (see figure 14).

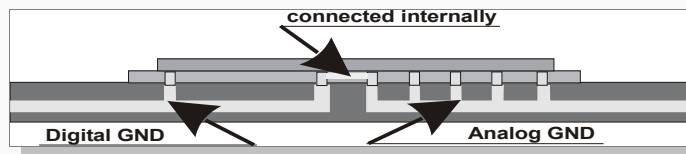

Figure 14: Ground plane of the JP13-LP family GPS receivers

9.2 RF connection

The JP13-LP family GPS receiver is designed to be functional by using either a passive patch antenna or an antenna connector with standard RF cables. In order to make a properly RF connection, the user has to connect the antenna points or the pins of the connector to the RF pin (RF_IN, see tables 3, 4 and Table 5.) and RF grounds (GND's of RF part), respectively (see figures below).

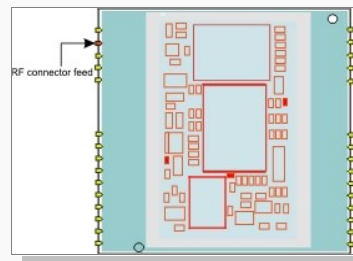

Figure 15: RF connection to antenna feed of the JP13-LP GPS receiver with edge contacts.

Recommendations for layout, and soldering. Please note that, the dimension tolerance is ± 0.1 mm.

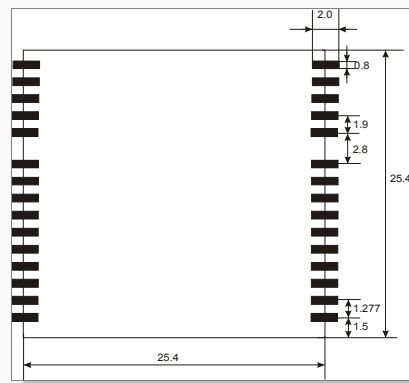

Figure 16: Recommendations for layout (JP13-LP with edge contacts).

Figure 17 shows the recommended solder profile for Pb-free JP13-LP family units.

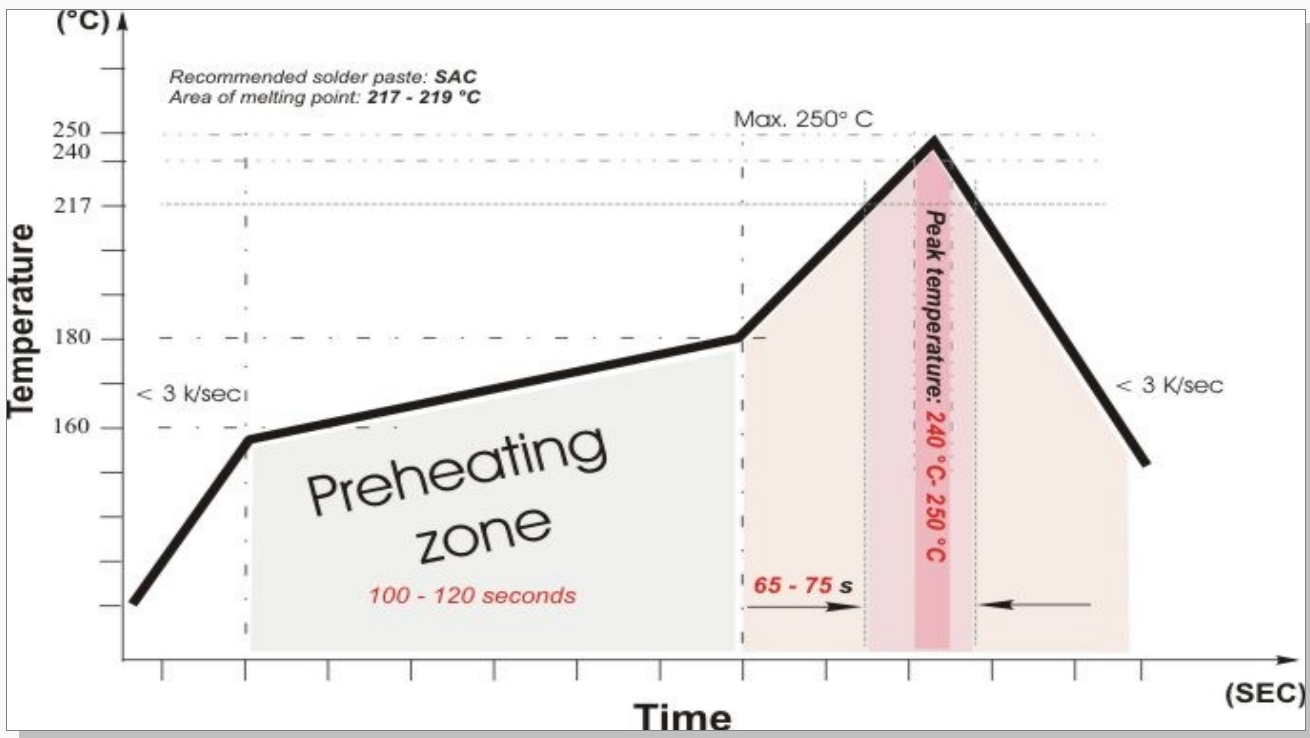

Figure 17: Typical solder conditions (temperature profile, reflow conditions).

Consider for a long time in the soldering zone (with temperature higher than 217 °C) has to be kept as short as possible to prevent component and substrate damages. Peak temperature must not exceed 250 °C.

Please note that, this soldering profile is a reference to the soldering machine FALCOM utilizes. This profile can vary by using different paste types, and soldering machines, and it should be adapted to the customer application. NO liability is assumed for any damage to the module caused while soldering.

Reflow profiles in tabular form

Profile Feature	Values
Ramp-Up Rate	< 3 K/second
Preheat- zone	
– Temperature Range	160-180°C
– Time	100-120 seconds
Peak-zone:	
– Peak Temperature	240°C .. 250°C max.
– Time above 217°C	65-75 seconds
Ramp-Down Rate	< 3 K/second

Note: JP13-LP module can accept only one reflow process

10 FIRST STEPS TO MAKE IT WORKS

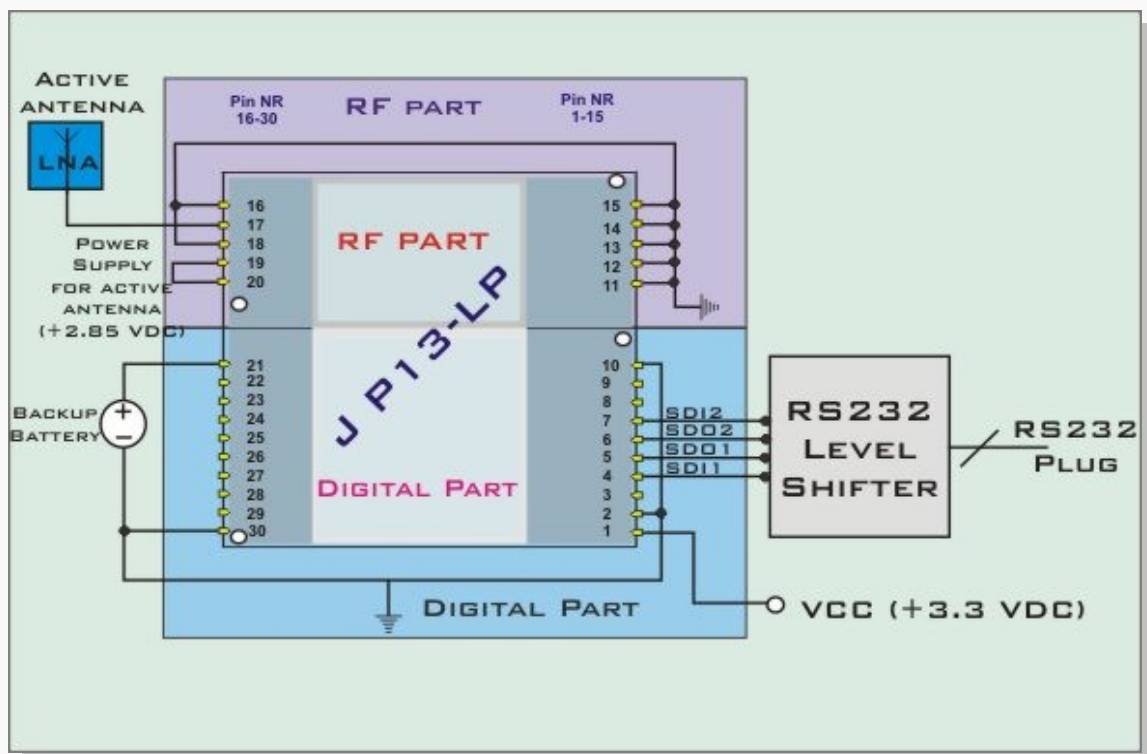

Figure 18: The minimum hardware interface of JP13-LP (with edge contacts) to get started.

Antenna:

The antenna connection is the most critical part of PCB routing. Before placing the JP13-LP on the PCB, secure that the connection to the antenna signals is routed. In order to make it properly functional, a control impedance line has to connect the RF_IN signal with antenna feed points or antenna connector, respectively. The routing on the PCB depends on your choice.

Power:

The input power is also very important as far as the minimum and maximum voltage is concerned. The power supply of JP13-LP family has to be a single voltage source of VCC at 3.3 VDC $\pm 5\%$. Please, connect GND pins to ground, and connect the lines which supply the VCC pin to +3.3 V, properly. If they are correctly connected, the board is full powered and the unit begins obtaining its position fix.

Serial Interface:

The JP13-LP family provides two serial interfaces. Each interface is provided with two wires the SDI1 and SDO1 lines for the first serial interface (port A) and SDI2 and SDO2 lines for the second serial interface (port B). The current firmware does not support DGPS correction data. These pins are 3.3 V CMOS compatible. In order to use different voltage levels, an appropriate level shifter has to be used.

E.g. in order to provide RS232 compatible levels use the 3 V compatible MAX3232 transceiver from Maxim or others based on the required levels. The GPS data will be transmitted through port A (first serial port), if an active antenna is connected, which has a good view to sky. Pull-up (100 k Ω) to the unused SDI inputs.

Active Antenna Bias Voltage:

The output voltage at the antenna cable can be used to power the bias voltage of the antenna, provided can make sure that the antenna runs down to 2.7 V bias voltage and the current does not exceed 20 mA.

Backup Battery:

In case of a power interruption on pin **VCC** the real-time clock and backed-up SRAM are continually supplied through **V_BAT**. The voltage at this pin has to be +3 V DC $\pm 5\%$. If you do not use a backup battery, connect this pin to GND or leave it open.

The quickest way to get first results with the JP13-LP is to use the JP13-LP Evaluation board together with the program SiRFdemo.



Figure 19: Evaluation board with connected JP13-LP GPS receiver.

The Evaluation board contains:

- Evaluation Box
- JP13-LP sample with soldered antenna cable
- power supply (AC/DC adapter, Type FW738/05, Output 5VDC 1.3 A)
- active GPS antenna (FAL-ANT-3)
- RS232 level shifter
- RS232 cable to your computer
- Evaluation board user's manual

The Evaluation board with contained components are not included in the delivery package. The Evaluation board will have to be purchased separately.

The SiRFdemo manual and software are available on FALCOM's Website for free download:

- www.falcom.de | [Support](#) | [Download](#) | [Documentation](#) | [Sirf](#) | [SiRFdemo.pdf](#)
- www.falcom.de | [Support](#) | [Download](#) | [Documentation](#) | [Sirf](#) | [SiRFdemo.zip](#)

11 APPENDIX

11.1 How to set the target GPS receiver into power saving modes?

By means of SiRFDemo software version 3.81 from SiRF the user is able to configure this operation mode with desired setting.

The input message is accepted if the GPS receiver operates in the NMEA mode, else the input message will be ignored. The commands above cannot be implemented if the target receiver operates in the SiRF Binary mode.

In order to set the receiver into the ATP or PTF mode via input messages, start the SiRFDemo software version 3.81, select the COM port where GPS receiver is connected and the baud rate to 38400 bps, then open the COM port. If the receiver is operating in SiRF binary mode, switch it to the NMEA mode, select **Switch to NMEA protocol** from the **Action** menu of main window. After the receiver has obtained a GPS fix, it is able to be set in the ATP or PTF mode. To do this, open **Action** menu from main window and start **Transmit Serial Message** On the appeared dialog box select **NMEA...** protocol from the **Protocol Wrapper** option and type the following command onto the memo field as shown in the Figure 20:

PSRF107,1,400,2000,60000,60000,1 *(sets the target receiver into the ATP mode. Excluding \$-sign and checksum)*

After the message is correctly typed, send the defined message to the target unit by clicking the SEND button. The target device responds with **Acknowledged ...** if the sent message is accepted by the target unit.

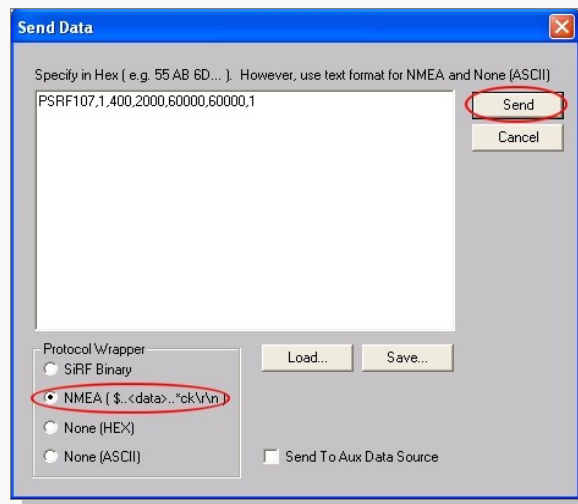

Figure 20: Transmit a NMEA message to the target unit.

To set the target receiver back to the full power mode just transmit the following message:

PSRF107,0,0,0,0,0 *It sets the target receiver back to full power mode*

For more information, how to send the SiRF Binary or NMEA messages to the target unit, please refer to the SiRFstarIII message set specification available in the section "Support/Downloads/Documentation/SiRF/SiRFmessages_SSIII.zip" at FALCOM homepage.