

RYBG211

2.4GHz Bluetooth 5.1
High power long range module
with Integrated Antenna

Datasheet

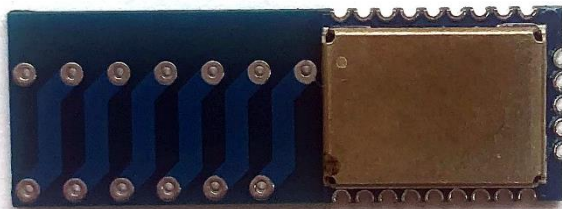

PRODUCT DESCRIPTION

The RYBG211 is a Bluetooth V5.1 Low Energy Module.

By using the AT command which is developed by REYAX, your products could be fast and easily connected with the smartphones and all kinds of Bluetooth devices.

FEATURES

- Bluetooth V5.1 with Bluetooth Low Energy.
- SILABS EFR32BG21A020F512IM32-B 32-bit ARM® Cortex®-M33 core industry-standard chip.
- Can connect 8 Host-Client RYBG21x modules at the same time.
- Metal cover against EMI interference.
- Control easily by AT commands.
- Standard Generic Attribute Profile (GATT).
- Designed with PCB integrated antenna.

APPLICATIONS

- Smart phone/Tablet accessories.
- Remote monitoring and control.
- Smart home.
- Indoor positioning.

APPROVED CERTIFICATIONS

SPECIFICATION

Item	Min.	Typical	Max.	Unit	Condition
Operation Voltage	1.71	3.3	3.8	V	VDD
RF Output Power		18.5	20	dBm	
Active Current		185	200	mA	
Advertising Average Current		6		mA	
Sleep Current		5		uA	
Wake Up Time		63		ms	
UART Baud Rate		9600	115200	bps	
RF Frequency Range	2400		2483.5	MHz	
Flash erase cycles		10		K	Cycles
Operating Temperature	-40	25	+85	°C	
Antenna					Internal Antenna
Weight		1.2		g	

PIN DESCRIPTION

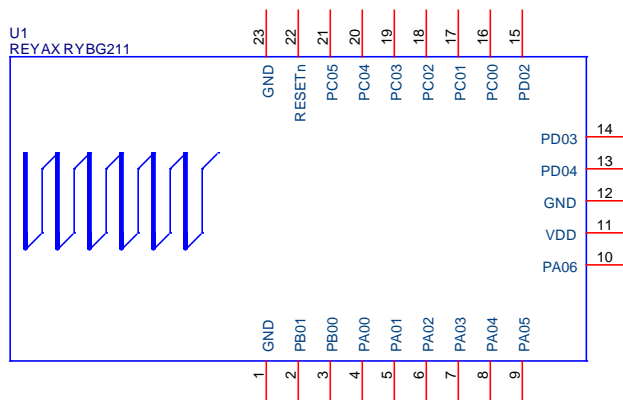

Pin	Name	I/O	Condition
1	GND	-	Ground
2	PB01	I/O	Reserved
3	PB00	I/O	Reserved
4	PA00	I/O	Reserved
5	PA01/SWCLK	I/O	Reserved
6	PA02/SWDIO	I/O	Reserved
7	PA03/SWO	I/O	Reserved
8	PA04	I/O	Reserved
9	PA05/TXD	O	UART Data Output
10	PA06/RXD	I	UART Data Input
11	VDD	I	Power Supply
12	GND	-	Ground
13	PD04	I/O	Reserved
14	PD03	I/O	Reserved
15	PD02	I/O	Reserved
16	PC00	I/O	Reserved
17	PC01	I/O	Reserved
18	PC02	I/O	Reserved
19	PC03	I/O	Reserved
20	PC04	I/O	Reserved
21	PC05	I/O	Reserved
22	RESETn	I	Low Reset
23	GND	-	Ground

APPLICATION SCHEMATIC

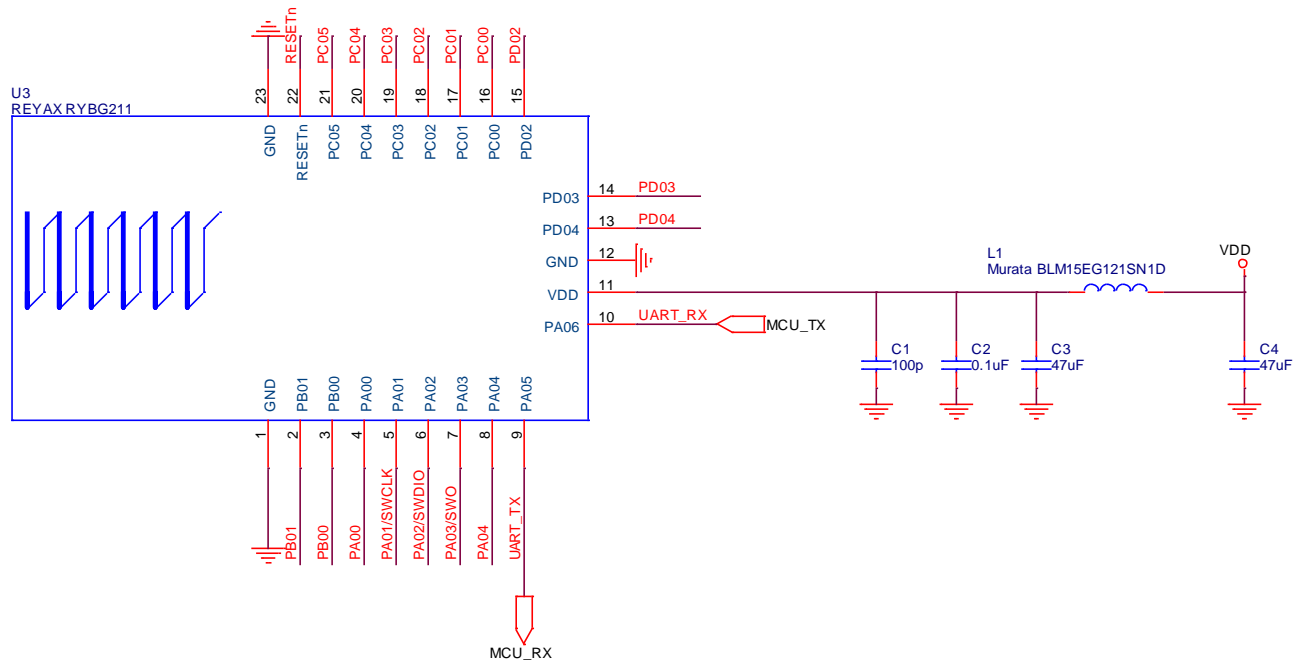

BLOCK DIAGRAM

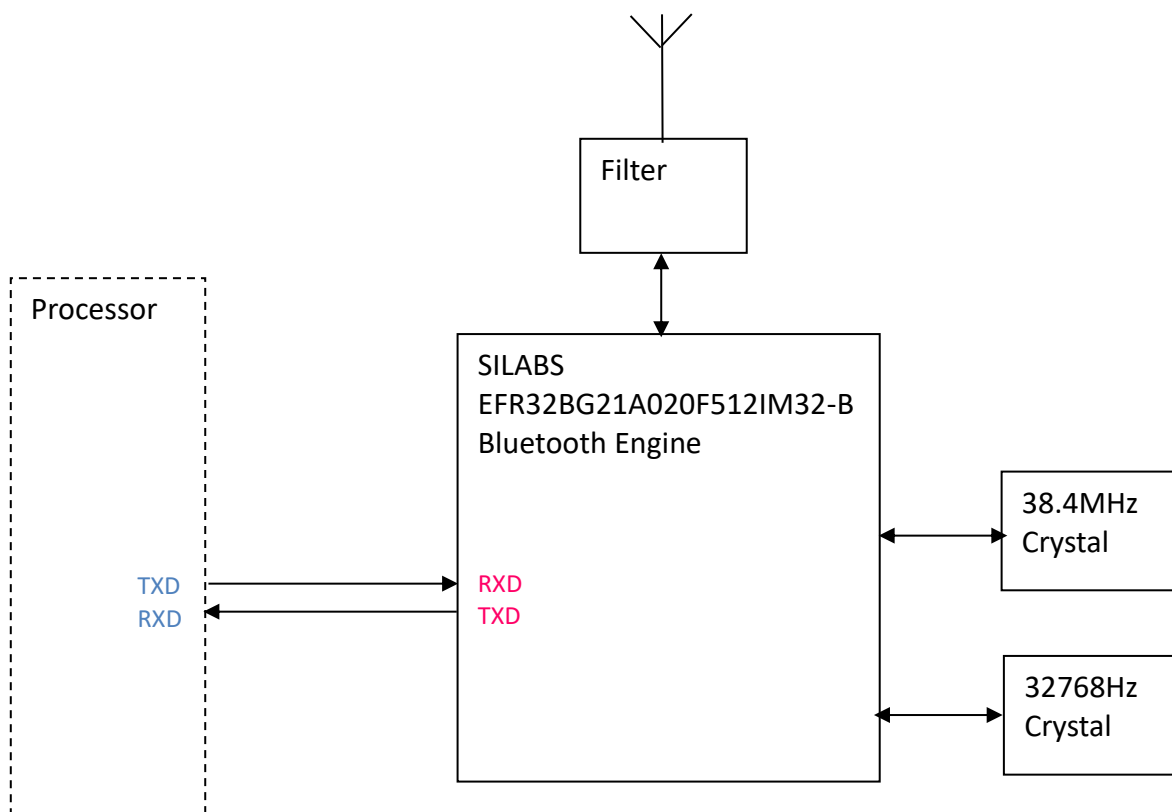

REFLOW SOLDERING

Consider the "IPC-7530 Guidelines for temperature profiling for mass soldering (reflow and wave) processes, published 2001.

Preheat phase

Initial heating of component leads and balls. Residual humidity will be dried out. Please note that this preheat phase will not replace prior baking procedures.

- Temperature rise rate: max. 3 °C/s If the temperature rise is too rapid in the preheat phase it may cause excessive slumping.
- Time: 60 - 120 s If the preheat is insufficient, rather large solder balls tend to be generated. Conversely, if performed excessively, fine balls and large balls will be generated in clusters.
- End Temperature: 150 - 200 °C If the temperature is too low, non-melting tends to be caused in areas containing large heat capacity.

Heating/ Reflow phase

The temperature rises above the liquidus temperature of 217°C. Avoid a sudden rise in temperature as the slump of the paste could become worse.

- Limit time above 217 °C liquidus temperature: 40 - 60 s
- Peak reflow temperature: 245 °C

Cooling phase

A controlled cooling avoids negative metallurgical effects (solder becomes more brittle) of the solder and possible mechanical tensions in the products. Controlled cooling helps to achieve bright solder fillets with a good shape and low contact angle.

- Temperature fall rate: max 4 °C/s To avoid falling off, the REYAX RYB070I module should be placed on the topside of the motherboard during soldering.

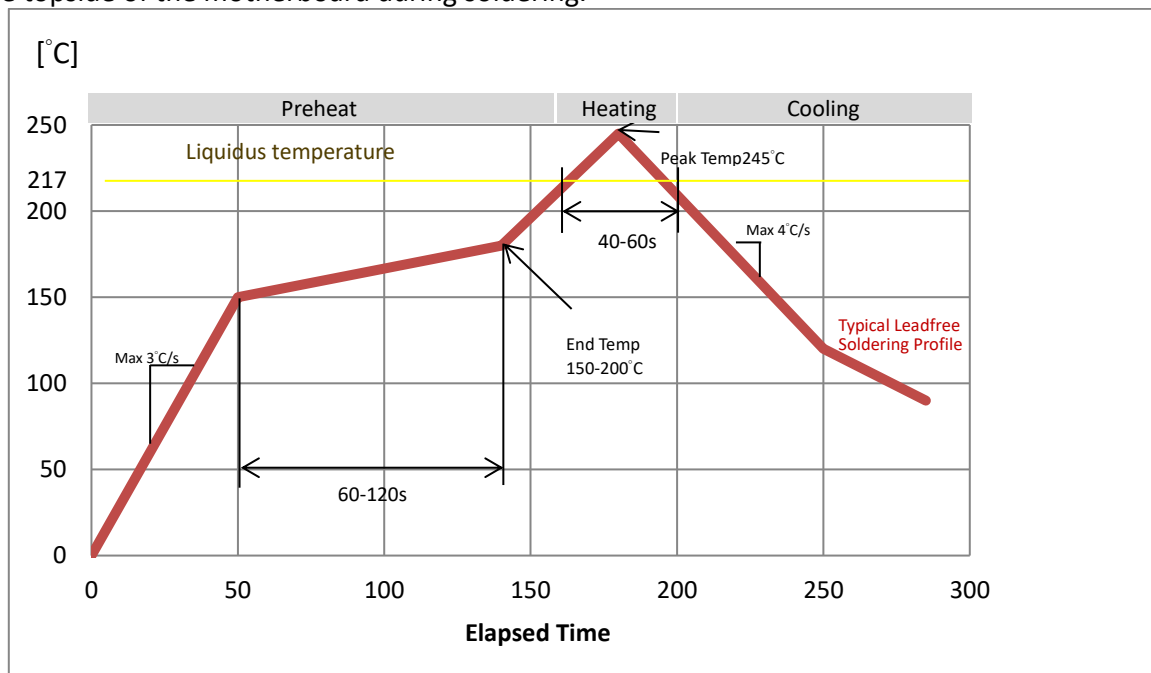

Recommended soldering profile

*Note: Does not support upside-down/bottom side reflow.

DIMENSIONS

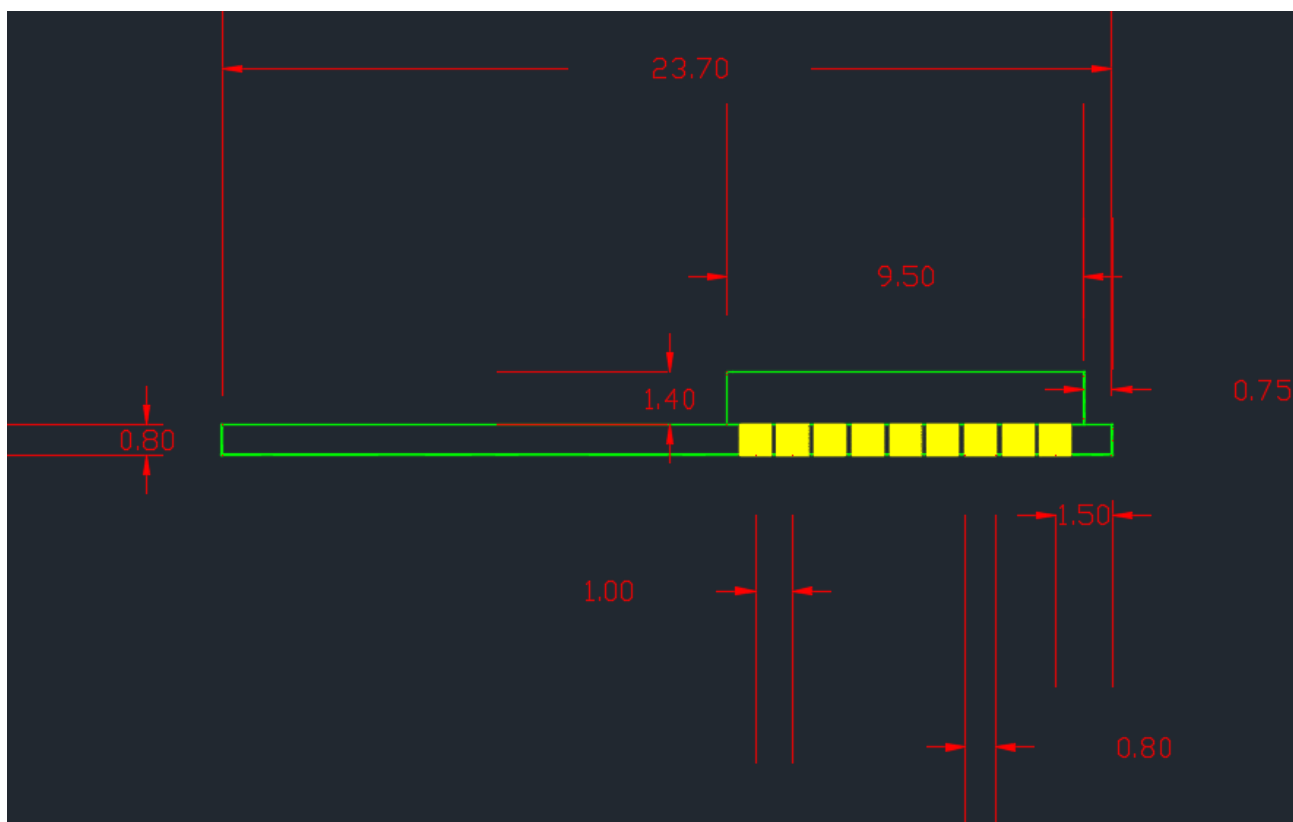
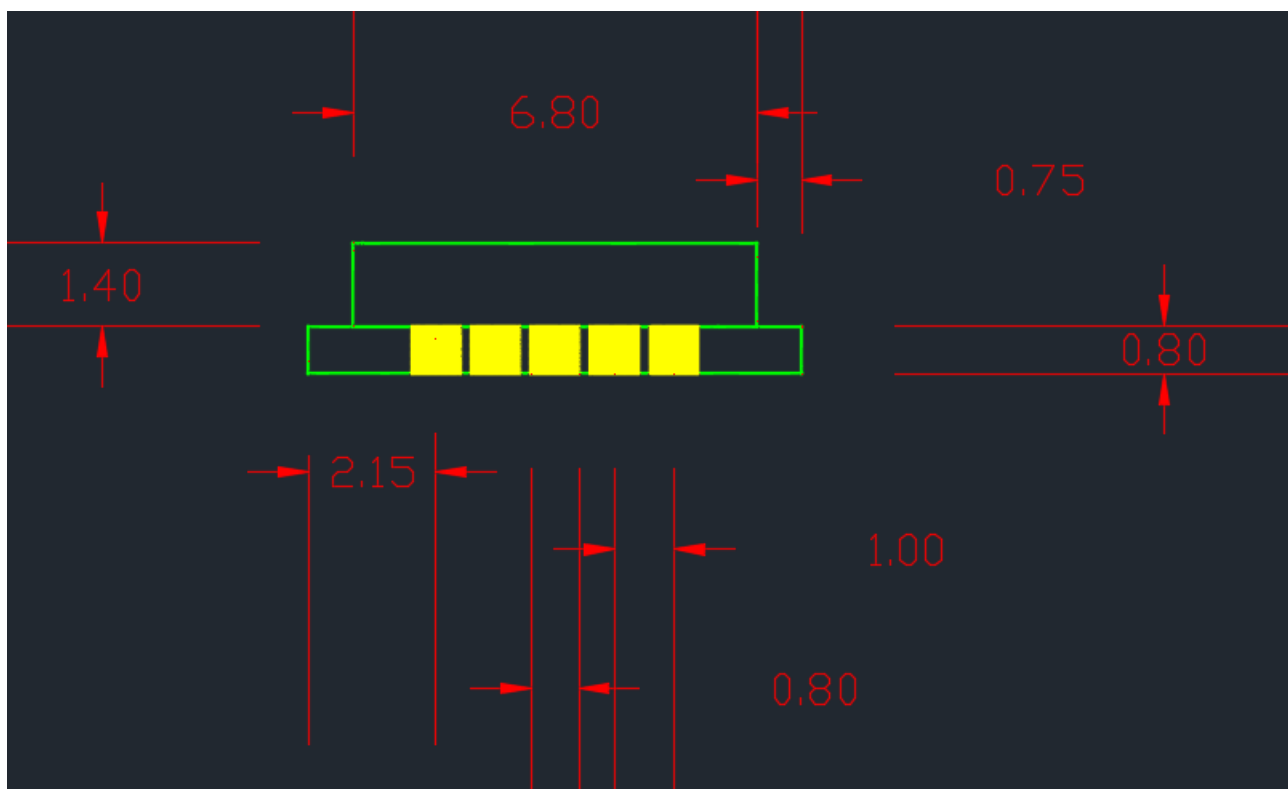

Unit : mm

LAYOUT FOOTPRINT RECOMMENDATIONS

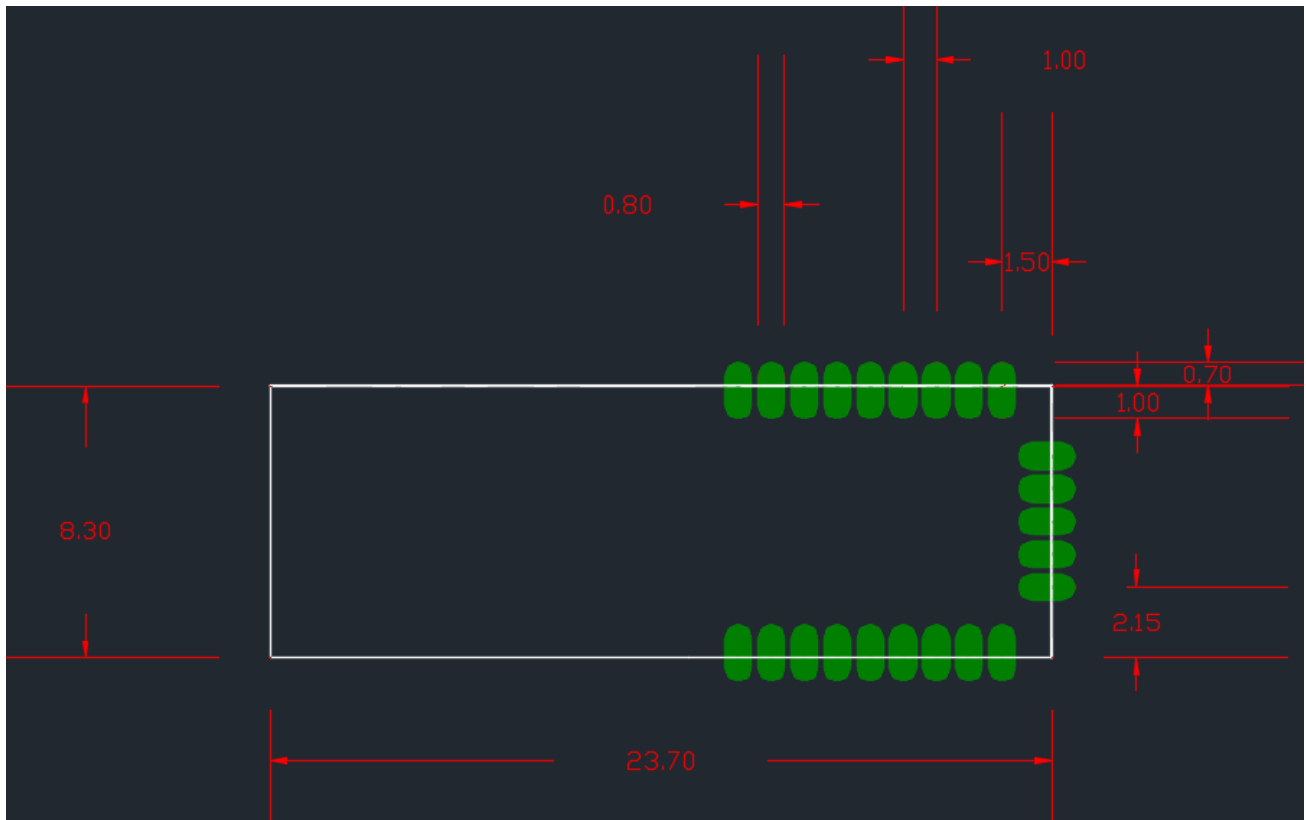

Unit : mm

ORDER INFORMATION

Ordering No.	Function	Firmware version
RYBG211		

REYAX
TECHNOLOGY CORPORATION, LTD

Taiwan: sales@reyax.com
China: sales@reyax.com.cn
<http://reyax.com>