



Enabling Industrial IoT



## QUARTZ-GOLD-5G

Compact 5G NR Gigabit Ethernet Industrial Router Range

Applicable models:

QUARTZ-GOLD-W21-5G (GL)

QUARTZ-GOLD-21-5G (GL)

Hardware Reference Manual

Rev 1.3



# Table of Contents

<b>Introduction</b>	<b>3</b>	<b>Antenna Connectors</b>	<b>31</b>
<b>About Siretta</b>	<b>4</b>	Cellular Antenna Connector	31
<b>General Description</b>	<b>5</b>	Wi-Fi Antenna Connector	32
Typical Installation	6	<b>Copyright Information</b>	<b>34</b>
<b>Features</b>	<b>7</b>	Copyright Declarations	34
Physical Interfaces	7	Trademarks	34
Cellular Features	8	<b>Approvals</b>	<b>35</b>
<b>Specifications</b>	<b>9</b>	<b>Disclaimer</b>	<b>36</b>
Physical	9	<b>Definitions</b>	<b>37</b>
Power	9		
Power Consumption	10		
<b>Ordering Information</b>	<b>14</b>		
<b>Radio Characteristics</b>	<b>15</b>		
Wi-Fi Characteristics	15		
Cellular Characteristics	17		
Support Modulation	21		
Data Transmission Rates	21		
<b>Dimensions</b>	<b>22</b>		
<b>QUARTZ-GOLD-5G Images</b>	<b>23</b>		
<b>Status LED</b>	<b>25</b>		
<b>Interfaces</b>	<b>26</b>		
LAN/WAN Port	27		
RS232/RS485 Interface	28		
Earth Point	29		
Reset	29		
<b>SIM Socket</b>	<b>30</b>		



## Introduction

This document covers all the radio, electrical and mechanical aspects of the QUARTZ-GOLD-5G NR router. For programming and use of this product in a computer network, please refer to the QUARTZ-GOLD-5G Software Manual.

This manual is intended to guide on how to connect the QUARTZ-GOLD-5G router into a computer network so that it may be used as the gateway router either to a WAN or the 5G NR cellular network, with the option of automatic fallback between the two. For complete network configuration, it is necessary to set up the network using the built-in web server for which reference to the companion software manual is required.

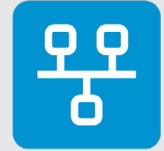

## About Siretta

Siretta is a wireless communications company located in Reading, United Kingdom manufacturing & supplying industrial IoT products since 1998.

Siretta's product portfolio is made up of:

- » Antennas, plus their associated Cable Assemblies & Adapters,
- » Cellular Network Analysers
- » Industrial Modems
- » Industrial Routers
- » Associated Cloud Management

Siretta supplies products directly and via a worldwide network of distributors, into numerous markets and applications across the globe.

Siretta's distribution partners range from industrial IoT specialists through to global catalogue organisations.

Whether "off the shelf" or custom solutions are required, Siretta has a wide portfolio of products to fit many types of application.

Siretta's extensive knowledge and experience in the wireless market allows support of a wide range of customer applications, focusing on frequencies between 400 MHz to 6 GHz. These encompass modems, routers and antennas for:

- » Cellular technologies: GSM / UMTS / LTE (including Cat M & NB) / 5G NR and other cellular technologies as they emerge.
- » Global positioning: GPS/GNSS
- » WLAN/Wi-Fi

Whilst providing the above products for the industrial cellular market, Siretta also has a number of antennas to cover applications for:

- » Bluetooth, Zigbee, ISM band, LoRa and Sigfox

With a heavy emphasis on design, Siretta has a team of dedicated Engineers and Product Managers, who specialise in wireless applications.

Siretta continually makes significant investment in R&D endeavouring to provide customers with market leading, future-proofed, wireless solutions. Siretta works closely with many technology partners to stay at the forefront of industrial IOT.

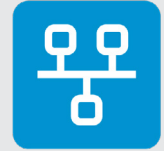

## General Description

The QUARTZ-GOLD-5G uses a Mediatek 880 MHz MIPS dual-core processor with 256 Mb flash and 2 Gb of DDR3 RAM. This processor runs a Linux based Operating System which controls the web interface and routing functionality of the router. VPN throughput is enhanced with a hardware IPSec crypto engine onboard the MIPS processor.

The cellular capabilities of the QUARTZ-GOLD-5G are powered by the Quectel RM520N-GL Module. This uses the Qualcomm Snapdragon X55 5G Modem which is manufactured on a leading edge 7 nm semiconductor fabrication process.

As well as offering two Gigabit Ethernet interfaces, the QUARTZ-GOLD-5G also offers an RS232 interface that may be used to connect serial ports on products such as door access controllers and alarm panels to the Internet.

Wi-Fi 5 (802.11ac) comes as an option, with backward compatibility modes allowing both 2.4 GHz and 5 GHz frequency operation to be supported.

Three modes of networking operation are possible:

1. 5G NR cellular router where the WAN connection of the router is the 5G NR cellular interface. In this mode all Ethernet interfaces are for LAN use. Internet connectivity comes from the internal cellular interface.
2. WAN router where one of the Ethernet ports of the router is used as the WAN connection. The WAN port in this case would normally be connected to a cable or ADSL modem to obtain Internet connectivity.
3. Backup router which combines the two above modes. The router can switch between the cellular and WAN connections automatically to maintain Internet connectivity should one path fail. The preferred route can be set to cellular or WAN.

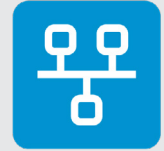

## Typical Installation

This section explains the interfaces on the QUARTZ-GOLD-5G and how to connect to them. It is recommended that the SIM card necessary for Cellular operation be inserted into the QUARTZ-GOLD-5G first and power applied last.

A typical installation will look like this:

Figure 1. Typical system diagram

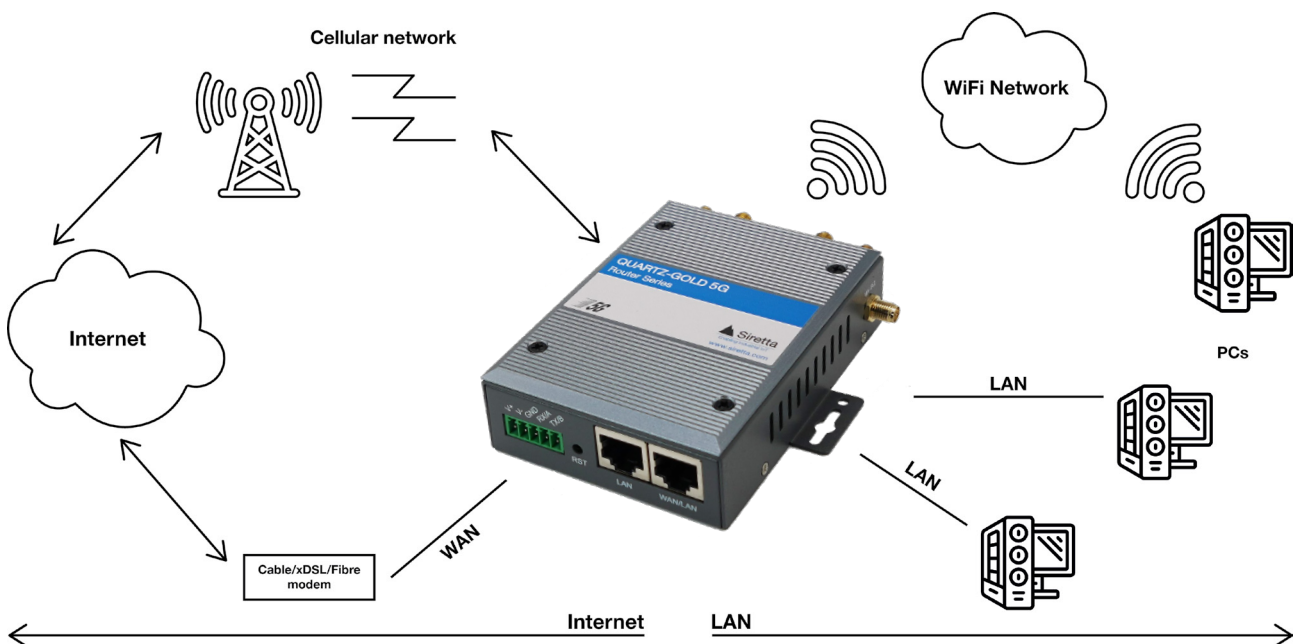

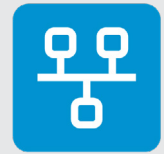

# Features

## Physical Interfaces

- » 2x Gigabit RJ-45 Ethernet Interfaces
- » 1x SIM Slot
- » 1x DC Power Interface (7.5 to 32 V dc)
- » 4x SMA Cellular Interface
- » 2x RP-SMA Wi-Fi Interface (on models supporting Wi-Fi)
- » Serial interface that may be configured as RS232 or RS485/Modbus (RS485/Modbus is an optional feature that must be ordered at time of purchase)

## Physical

- » Galvanised steel box with grounding point
- » Wide operating temperature range
- » Supplied with mounting tabs to attach to a flat surface such as a wall or cabinet

## LED Indication

- » Power – Power applied
- » Cellular Signal – signal quality & connection status
- » LAN – connection status and activity
- » WAN – connection status and activity
- » WLAN – connection status and activity
- » Error – Cellular online/offline status

## LAN/WAN Features

- » 1x Gigabit LAN & 1x Gigabit LAN/WAN (user configurable)
- » Hardware NAT capable of 2 Gbps wire speed
- » Auto-MDI/MDIX

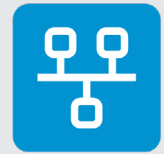

### Cellular Features

- » Support for 5G NR (NSA & SA), LTE (4G) and WCDMA (3G) networks
- » Network locking
- » Network disconnection checking
- » Rx Diversity on all network types

### 5G NR Features

- » Supports 3GPP Release 16 features
- » Supports NSA (Non-Standalone Architecture) and SA (Standalone Architecture) modes of operation
- » Supports FDD and TDD modes
- » Supports Frequency Range 1 bands (Sub 6 GHz bands)
- » MIMO support (4x4 Download, 2x2 Upload)
- » Maximum downlink speed 2.4 Gbps (SA mode); 3.4 Gbps (NSA mode)
- » Maximum uplink speed 900 Mbps (SA mode); 550 Mbps (NSA mode)

### LTE (4G) Features

- » Supports Cat 19 download and Cat 18 upload speeds
- » Supports FDD and TDD modes
- » Supports MIMO in download direction
- » Maximum downlink speed 1.6 Gbps
- » Maximum uplink speed 200 Mbps

### WCDMA (3G) Features

- » Supports 3GPP Release 9 features DC-HSDPA, HSPA+, HSDPA, HSUPA and WCDMA
- » Maximum downlink speed 42 Mbps (DC-HSDPA)
- » Maximum uplink speed 5.76 Mbps (HSUPA)

### Wi-Fi Features

- » IEEE 802.11n/ac radio supporting IEEE 802.11a/b/g/n/ac wireless standards
- » Concurrently operates in 2.4 and 5 GHz bands
- » Standard Reverse Polarity SMA antenna interface
- » Access point, Client, and Ethernet bridge modes of operation
- » 20/40/80 MHz channel width

### VPN Features

- » Hardware Crypto Engine delivering 400~500 Mbps IPSec throughput

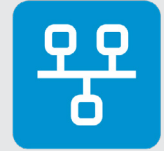

# Specifications

## Physical

### Environmental

Table 1. Environmental Characteristics

Parameter	Value
Operating Temperature	-30 to +75°C
Storage Temperature	-40 to +85°C
Humidity Range	0 to 95% RH non-condensing

### Mechanical

Table 2. Mechanical Characteristics

Parameter	Value
Dimensions	102.6 mm x 73.5 mm x 27.7 mm (excluding protruding connectors)
Weight	306 g (excluding antennas, SIM card, connectors and packaging)
IP Rating	30

## Power

### Power Supply Requirements

Table 3. Power Supply Requirements

Parameter	Value
Input supply voltage	7.5 – 32 V
Minimum power supply rating	24 W
Recommended Power Supply	12 V @ 2.0 A



## Power Consumption

Table 4. Power Consumption Characteristics when connected to LTE cell

Cellular	Wi-Fi	Configuration	Measured Power	Operating Mode
On	Off	2x LAN	230 mA	No interfaces connected
On	2.4G & 5G	2x LAN	270 mA	No interfaces connected
On	Off	2x LAN	265 mA	LAN connected to PC, PC network activity idle
On	Off	2x LAN	290 mA	LAN connected to PC, PC streaming video (Sky News)
On	Off	2x LAN	420 mA	LAN connected, running a speedtest (speed achieved 103 Mbps download, 11.40 Mbps upload)
On	2.4G	2x LAN	255 mA	LAN disconnected, PC connected to 2.4G Wi-Fi but activity idle
On	2.4G	2x LAN	270 mA	LAN disconnected, PC connected to 2.4G Wi-Fi and streaming video (Sky News)
On	2.4G	2x LAN	415 mA	LAN disconnected, PC connected to 2.4G Wi-Fi and running a speedtest (speed achieved 74.6 Mbps download, 17.94 Mbps upload)
On	5G	2x LAN	255 mA	LAN disconnected, PC connected to 5G Wi-Fi but activity idle
On	5G	2x LAN	280 mA	LAN disconnected, PC connected to 5G Wi-Fi and streaming video (Sky News)
On	5G	2x LAN	395 mA	LAN disconnected, PC connected to 5G Wi-Fi and running a speedtest (speed achieved 52.49 Mbps download, 19.28 Mbps upload)
Off	2.4G & 5G	1x WAN, 1xLAN	295 mA	WAN connected to broadband router, LAN and Wi-Fi disconnected
On	2.4G & 5G	1x WAN, 1xLAN	295 mA	WAN connected to broadband router, LAN and Wi-Fi disconnected
On	2.4G & 5G	1x WAN, 1xLAN	325 mA	WAN connected to broadband router, LAN connected to PC, PC network activity idle, Internet connection via WAN
On	2.4G & 5G	1x WAN, 1xLAN	325 mA	WAN connected to broadband router, LAN connected to PC, PC streaming video (Sky News), Internet connection via WAN
On	2.4G & 5G	1x WAN, 1xLAN	360 mA	WAN connected to broadband router, LAN connected to PC, PC streaming video (Sky News), Internet connection via Cellular (WAN backup, broadband connection fail)

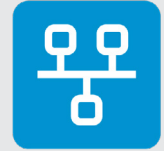

1. All measurements were done with 12V input.
2. Current consumption figures given in the table above are average current measurements over 15 minutes and are not estimates. When the cellular connection is active there will be short current pulses significantly greater than the average values provided. It is important that the 12V supply used to power the router can deliver at least 2.0 A to prevent network disconnections caused by these current pulses.
3. All current measurements are started after the router has been rebooted with the test configuration and time allowed for the router to connect onto the cellular network, settle on a cell, and get an Internet connection.
4. Sky News may be accessed at <https://news.sky.com/watch-live>. The news video is an embedded YouTube frame. It should be possible to access internationally (if not, try using a VPN). When viewed, quality is set to 1080p and viewed full screen.
5. Speedtests were conducted using the web site <https://www.speedtest.net>. Current measurement is from clicking 'go' on the website to the speed measurement results being displayed. Speeds achieved are limited to the capability of the cellular cell connected to, and in the case of measurements done over Wi-Fi, also the capabilities of the Wi-Fi connection.
6. The power consumption when used with UMTS, LTE and 5G NR networks is broadly similar for like connection speeds. Cellular power consumption will be affected more strongly by proximity to the serving cell (closer to the cell = less transmitting power required), weather (heavy rain/snow = more signal attenuation and greater transmit power) and operating band (lower frequencies are generally lower power). Measurements in the table above were conducted with the CSQ reported on the status page typically 15 with the connection on band 3 (1800 MHz). A 5G SA connection on band n78 (3500 MHz) using 2x2 MIMO is the highest power consumption and can be expected to elevate the measured values by as much as 350 mA at full data rate.

### Sim Card reader

SIM card reader for mini-SIM (2FF) meeting ISO/IEC 7810:2019, ID-000 (25 mm x 15 mm)

Table 5. SIM Card Reader Characteristics

Parameter	Value
SIM card reader type	Draw type with card detection switch
SIM card voltage support	1.8 V and 3 V with automatic detection



#### RS232 characteristics

The RS232 port is 2-wire (no flow control). The RS232 port may be used in either client or server mode (server mode requires either a fixed IP address SIM or a VPN to be configured). Caching of serial data is supported for areas where Internet access is intermittent.

Table 6. RS232 Configuration Settings

Setting	Allowed Values
Baud Rate	300, 600, 1200, 2400, 9600, 19200, 38400, 57600, 115200
Data bits	5, 6, 7, 8
Parity	None, odd, even
Stop bits	1, 2

**IMPORTANT:** Baud rates settings are valid with a load of 3k $\Omega$ , 1000pF

Table 7. RS232 Transmitter Characteristics

Transmitter Parameter	Conditions	Min	Typ	Max	Units
Output Voltage Swing	3k $\Omega$ load to ground	$\pm$ 5.0	$\pm$ 5.4		Volts
Output short circuit current			$\pm$ 35	$\pm$ 60	mA

Table 8. RS232 Receiver Characteristics

Receiver Parameter	Min	Typ	Max	Units
Voltage Range	-15		15	Volts
Threshold Low	0.6	1.3		Volts
Threshold High		1.7	2.4	Volts
Hysteresis		0.3		Volts
Resistance	3	5	7	k $\Omega$

**IMPORTANT:** Minimum and maximum values are over the operating temperature range of -30 to +75°C, typical values are at +25°C.

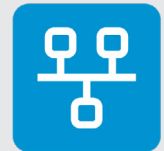

#### RS485 characteristics

The RS485 port is 2-wire (no flow control). One for transmitting data (TX) and one for receiving data (RX). The RS485 port may be used in either client or server mode (server mode requires either a fixed IP address SIM or a VPN to be configured). Serial data caching is supported to accommodate for regions with intermittent internet connectivity.

Table 9. RS485 Characteristics

Setting	Allowed Values
Baud rate	300, 600, 1200, 2400, 9600, 19200, 38400, 57600, 115200
Data bits	5, 6, 7, 8
Parity	None, odd, even
Stop bits	1, 2

Table 10. Transmitter Parameter

Setting	Conditions	Min	Typ	Max	Units
Differential output voltage	With a 27 $\Omega$ load	1.5		Vcc (3.3)	Volts
Output short circuit current V out =HIGH/LOW				$\pm 250$	mA
Input low voltage				0.8	Volts
Input high voltage	2.0				Volts

Table 11. Receiver Parameter

Setting	Min	Typ	Max	Units
Differential input threshold	-0.2		0.2	
Input Hysteresis		20		mV
Output voltage LOW			0.4	Volts
Output voltage HIGH	Vcc-0.4			Volts
Threshold High	2.9			
Input resistance	12			k $\Omega$

#### LAN characteristics

2x 10/100/1000 Mbps Ethernet RJ45 Ports. One port is for LAN only. The other port may be software configured as a LAN or a WAN port.

Although the maximum speed if any individual port is 1 Gbps, the switching matrix supporting the two ports is capable of 2 Gbps wire speed.

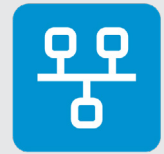

## Ordering Information

### Compact Industrial 5G Quad Gigabit Ethernet Router

QUARTZ-GOLD-21-5G (GL) - Stock Code 61901  
QUARTZ-GOLD-21-5G (GL) + ACCESSORIES - Stock Code 61902

### Dual WiFi Compact Industrial 5G Quad Gigabit Ethernet Router

QUARTZ-GOLD-W21-5G (GL) – Stock code 61867  
QUARTZ-GOLD-W21-5G (GL) + ACCESSORIES - Stock Code 61896

All routers may be ordered with RS485/Modbus serial interface. This is an optional feature. Please contact Siretta sales for details.

The accessories kit contains all the other components required to be able to use the router:

- » 2 swivel joint WLAN antennas (Wi-Fi models only)
- » 4 swivel joint Cellular antennas supplied with detachable magnetic mount bases with 3m of cable
- » RJ45 Ethernet cable
- » Multi-region 2A, 12V power supply

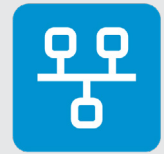

# Radio Characteristics

## Wi-Fi Characteristics

The QUARTZ-GOLD-5G supports Wi-Fi using a MediaTek radio that is IEEE802.11n/ac compliant. This means that it will work with other Wi-Fi adapters supporting IEEE 802.11a/b/g/n/ac. The 2.4 GHz and 5 GHz wireless bands may be independently configured.

2.4 GHz bands may be set to 20 or 40 MHz channel width.

5 GHz bands may be set to 20, 40 or 80 MHz channel width.

A channel configured for 2.4 GHz operation may be used as 802.11b only, 802.11g only, 802.11b/g mixed and 802.11n only, as well as the default 802.11b/g/n mixed mode (configured by software).

A channel configured for 5 GHz operation can be used as 802.11a only and 802.11n only, as well as the default 802.11ac mixed mode (configured by software).

## Wi-Fi Channels Supported

Table 12. 2.4 GHz Wi-Fi band support

Channel Number	Centre frequency	Frequency Range
1	2412 MHz	2401 – 2423 MHz
2	2417 MHz	2406 – 2428 MHz
3	2422 MHz	2411 – 2433 MHz
4	2427 MHz	2416 – 2438 MHz
5	2432 MHz	2421 – 2443 MHz
6	2437 MHz	2426 – 2448 MHz
7	2442 MHz	2431 - 2453 MHz
8	2447 MHz	2436 – 2458 MHz
9	2452 MHz	2441 – 2463 MHz
10	2457 MHz	2446 – 2468 MHz
11	2462 MHz	2451 – 2473 MHz
12	2467 MHz	2456 – 2478 MHz
13	2472 MHz	2461 – 2483 MHz
14	2484 MHz	2473 – 2495 MHz

**IMPORTANT:** While the QUARTZ-GOLD-5G can support all 2.4 GHz Wi-Fi channels, the regional settings in the Wi-Fi configuration page will limit the available channels to meet the regulatory requirements of the country in which it is being used. Siretta always recommends that the region setting be correctly configured for the country in which the router is being used.

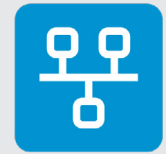
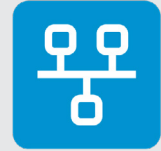

Table 13. 5 GHz Wi-Fi support

Channel Number	Centre frequency	Frequency Range
36	5.18 GHz	5.17 – 5.19 GHz
40	5.20 GHz	5.19 – 5.21 GHz
44	5.22 GHz	5.21 – 5.23 GHz
48	5.24 GHz	5.23 – 5.25 GHz
52	5.26 GHz	5.25 – 5.27 GHz
56	5.28 GHz	5.27 – 5.29 GHz
60	5.30 GHz	5.29 – 5.31 GHz
64	5.32 GHz	5.31 – 5.33 GHz
100	5.50 GHz	5.49 – 5.51 GHz
104	5.52 GHz	5.51 – 5.53 GHz
108	5.54 GHz	5.53 – 5.55 GHz
112	5.56 GHz	5.55 – 5.57 GHz
116	5.58 GHz	5.57 – 5.59 GHz
120	5.60 GHz	5.59 – 5.61 GHz
124	5.62 GHz	5.61 – 5.63 GHz
128	5.64 GHz	5.63 – 5.65 GHz
132	5.66 GHz	5.65 – 5.67 GHz
136	5.68 GHz	5.67 – 5.69 GHz
140	5.70 GHz	5.69 – 5.71 GHz

**IMPORTANT:** While the QUARTZ-GOLD-5G can support most 5 GHz Wi-Fi channels, the regional settings in the Wi-Fi configuration page will limit the available channels to meet the regulatory requirements of the country in which it is being used. The regional setting also correctly applies transmit power and DFS requirements for the country of use. Siretta always recommends that the region setting be correctly configured for the country in which the router is being used.



## Wi-Fi Speed

Mode	Speed
2.4G only	150 Mbps
5G only	433 Mbps
2.4G + 5G	150 Mbps + 433 Mbps

## Cellular Characteristics

The QUARTZ-GOLD-5G supports the 3GPP specifications for cellular communications by using the Qualcomm Snapdragon X55 5G Modem.

## Cellular Frequency bands supported

Table 14. 5G NR SA and NSA Bands Supported

Band	Frequency	Duplex Mode	Common Name	4X4 MIMO DL	2x2 MIMO UL
n1	2100 MHz	FDD	IMT	●	●
n2	1900 MHz	FDD	PCS	●	●
n3	1800 MHz	FDD	DCS	●	●
n5	850 MHz	FDD	Cellular	●	●
n7	2600 MHz	FDD	IMT-E	●	●
n8	900 MHz	FDD	Extended GSM	●	●
n12	700 MHz	FDD	Lower SMH	●	●
n13	700 MHz	FDD	Upper SMH	●	●
n14	700 MHz	FDD	Upper SMH	●	●
n18	850 MHz	FDD	Lower 800	●	●
n20	800 MHz	FDD	Digital Dividend	●	●
n25	1900 MHz	FDD	Extended PCS	●	●
n26	850 MHz	FDD	Extender Cellular	●	●
n28	700 MHz	FDD	APT	●	●
n29	700 MHz	SDL	Lower SMH	●	●
n30	2300 MHz	FDD	WCS	●	●
n38	2600 MHz	TDD	IMT-E	●	●*
n40	2300 MHz	TDD	S-Band	●	●
n41	2500 MHz	TDD	BRS	●	●*
n48	3500 MHz	TDD	CBRS	●	●*

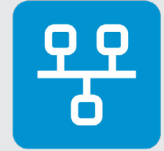

Table 14. 5G NR SA and NSA Bands Supported (Continued)

Band	Frequency	Duplex Mode	Common Name	4X4 MIMO DL	2x2 MIMO UL
n66	1700/2100 MHz	FDD	Extended AWS	●	●
n70	2000 MHz	FDD	Supplementary AWS	●	●
n71	600 MHz	FDD	Digital Dividend	●	●
n75	1500 MHz	SDL	L-Band (EU)	●	●
n76	1500 MHz	SDL	Extended L-Band (EU)	●	●
n77	3700 MHz	TDD	C-Band	●	●*
n78	3500 MHz	TDD	C-Band	●	●*
n79	4700 MHz	TDD	C-Band	●	●*

● Supported    ● Unsupported

**\*SA mode only**



## QUARTZ-GOLD-5G

### Hardware Manual

Table 15. LTE Bands Supported

Band	Frequency	Duplex Mode	Common Name	4X4 MIMO DL
1	2100 MHz	FDD	IMT	●
2	1900 MHz	FDD	PCS	●
3	1800 MHz	FDD	DCS	●
4	1700 MHz	FDD	AWS-1	●
5	850 MHz	FDD	Cellular	●
7	2600 MHz	FDD	IMT-E	●
8	900 MHz	FDD	Extended GSM	●
12	700 MHz	FDD	Lower SMH	●
13	700 MHz	FDD	Upper SMH	●
14	700 MHz	FDD	Upper SMH	●
17	700 MHz	FDD	Lower SMH	●
18	850 MHz	FDD	Lower 800	●
19	850 MHz	FDD	Upper 800	●
20	800 MHz	FDD	Digital Dividend	●
25	1900 MHz	FDD	Extended PCS	●
26	850 MHz	FDD	Extended Cellular	●
28	700 MHz	FDD	APT	●
29	700 MHz	FDD	Lower SMH	●
30	2300 MHz	FDD	WCS	●
32	1500 MHz	FDD	L-Band	●
34	2000 MHz	TDD	IMT	●
38	2600 MHz	TDD	IMT-E	●
39	1900 MHz	TDD	DCS-IMT Gap	●
40	2300 MHz	TDD	S-Band	●
41	2500 MHz	TDD	BRS	●
42	3500 MHz	TDD	CBRS	●
43	3700 MHz	TDD	C-Band	●
46 (LAA*)	5200 MHz	TDD	U-NII-1-4	●
48	3500 MHz	TDD	CBRS	●



Table 15. LTE Bands Supported continued

Band	Frequency	Duplex Mode	Common Name	4X4 MIMO DL
66	1700 MHz	FDD	Extended AWS	●
71	600 MHz	FDD	Digital Dividend	●

\*LAA (License Assisted Access). A method of using the unregulated 5 GHz wireless spectrum to assist data downloads, introduced in 3GPP Release 13.

Table 16. WCDMA (3G) Bands Supported

Band	Frequency	Common Name
1	2100 MHz	IMT
2	1900 MHz	PCS
4	1700 MHz	AWS-1
5	850 MHz	Cellular
8	900 MHz	Extended GSM
19	800 MHz	Upper 800

## Transmit Power

Table 17. Transmit Power

Technology	Class	Maximum Power
5G NR bands	3	23 dBm $\pm$ 2 dB
5G NR bands n38/n40/n41/n77/n78/n79 HPUE*	2	26 dBm +2/-3 dB
LTE (4G) bands	3	23 dBm $\pm$ 2 dB
LTE (4G) bands B38/B41/B42/B43 HPUE*	2	26 dBm $\pm$ 2 dB
WCDMA (3G) bands	3	24 dBm +1/-3 dB

\*HPUE (High Power User Equipment) is a special class of LTE allowed on a single carrier. Because of the higher allowed transmit power, this allows for a greatly increased range for the serving cell.

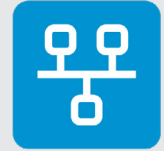

## Supported Modulation

Table 18. Modulation

Technology	Supported Modulation
5G NR Uplink	$\pi/2$ -BPSK, QPSK, 16QAM, 64QAM and 256QAM
5G NR Downlink	QPSK, 16QAM, 64QAM and 256QAM
LTE (4G) Uplink	QPSK, 16QAM, 64QAM and 256QAM
LTE (4G) Downlink	QPSK, 16QAM, 64QAM and 256QAM
WCDMA (3G)	QPSK, 16QAM and 64QAM

## Data Transmission Rates

Table 19. Data Transmission Rates

Technology	Maximum Download	Maximum Upload
5G NR SA	2.4 Gbps	900 Mbps
5G NR NSA	3.4 Gbps	550 Mbps
LTE (4G)	1.6 Gbps	200 Mbps
UMTS (3G) DC-HSDPA	42 Mbps	
UMTS (3G) HSUPA		5.76 Mbps
UMTS (3G) WCDMA	384 Kbps	384 Kbps

**IMPORTANT:** All upload and download speeds are those supported by the QUARTZ-GOLD-5G. Actual speeds achieved will be dependent on the capabilities of the network cell connected to, any network congestion, and the radio link quality.

## Dimensions

Figure 2. QUARTZ-GOLD-5G front view

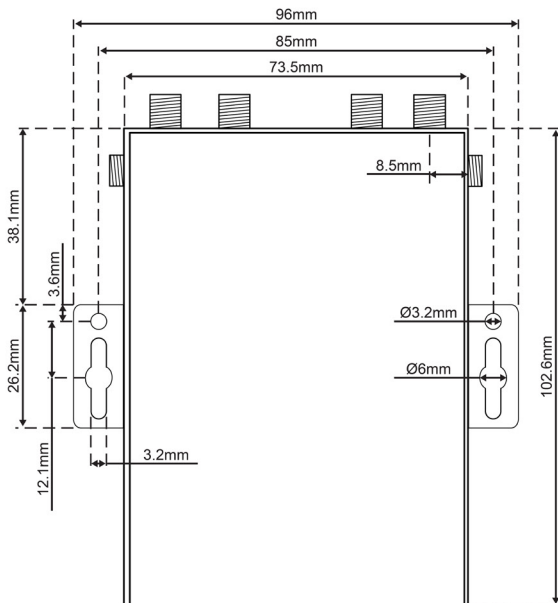

Figure 3. QUARTZ-GOLD-5G earthpoint

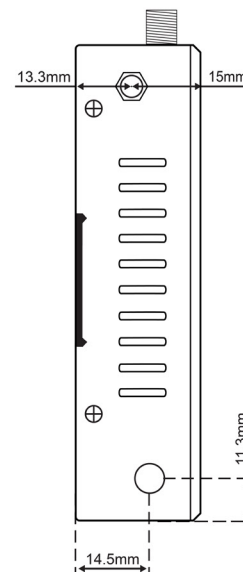

Figure 4. QUARTZ-GOLD-5G Power, reset and LAN/WAN interfaces

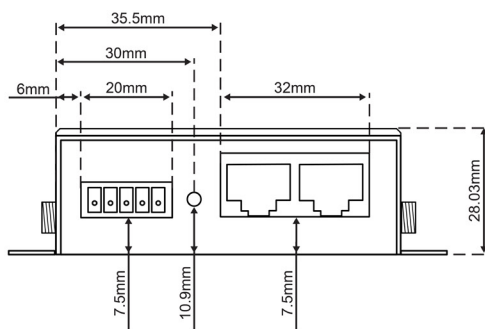
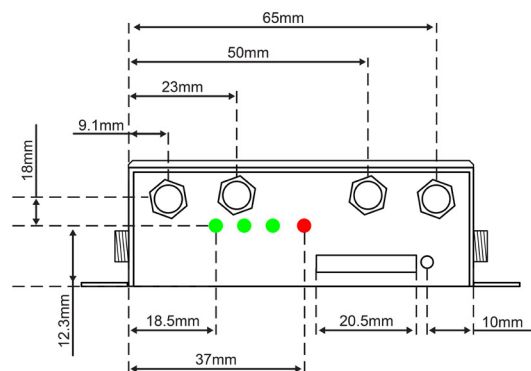

Figure 5. QUARTZ-GOLD-5G Antennas, LEDs and SIM Slot



## QUARTZ-GOLD-5G Images

Figure 7. 3D view of the QUARTZ-GOLD-5G Router



Figure 8. Front view of the QUARTZ-GOLD-5G Router



Figure 9. Power, Reset, LAN / WAN Interfaces, SIM Slot, LED, Cellular Antenna



Figure 10. Earth Point, Wi-Fi Antenna



## QUARTZ-GOLD-5G Hardware Manual

Figure 11. QUARTZ-GOLD-5G accessories



- 1 QUARTZ-GOLD-5G
- 2 Multi-head power adapter
- 3 Multi-region power adapter heads
- 4 Power cable connector
- 5 4G/5G antenna x4
- 6 2.4 GHz/ 5 GHz Wi-Fi Antenna x2 (optional with Wi-Fi version)
- 7 RJ-45 network cable
- 8 Magnetic Cellular Antenna Extenders x4

## Status LEDs



The status LEDs indicate activity on the QUARTZ-GOLD-5G interfaces. Note that while the LEDs may illuminate on or shortly after application of power, the status indication is not valid until approximately 60 seconds after the application of power.

Table 20. Router status LEDs

Label	Indication		Meaning
WLAN	Green	Solid	WLAN connected
		Blinking activity	WLAN connected, LAN network activity
		Off	WLAN disconnected
WAN	Green	Solid	WAN connected
		Blinking activity	WAN connected, WAN network activity
		Off	WAN disconnected
LAN	Green	Solid	LAN connected
		Blinking activity	LAN connected, LAN network activity
		Off	LAN disconnected
Cellular	Green (good cellular signal) Red (poor cellular signal)	Slow blink	Registering to cellular network / Cellular disabled / No SIM inserted
		Fast blink	Connected to cellular network, obtaining IP address
		Solid	Connected to cellular network & connected to Internet

**IMPORTANT:** On first power up, it may take 4-5 minutes for the QUARTZ-GOLD-5G to connect to the cellular network and for the cellular status LED to remain lit. On subsequent power-ups it should take considerably less time to connect to the cellular network. If the cellular status LED does not light continuously, check that the SIM card is inserted correctly, that the SIM is enabled by the network operator, that the correct APN and password settings have been entered (see QUARTZ-GOLD-5G software manual), and that the antennas have been correctly attached.

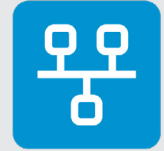

## Interfaces

Use the pictures below to identify the interfaces of the QUARTZ-GOLD-5G:

Figure 12. QUARTZ-GOLD-5G interfaces

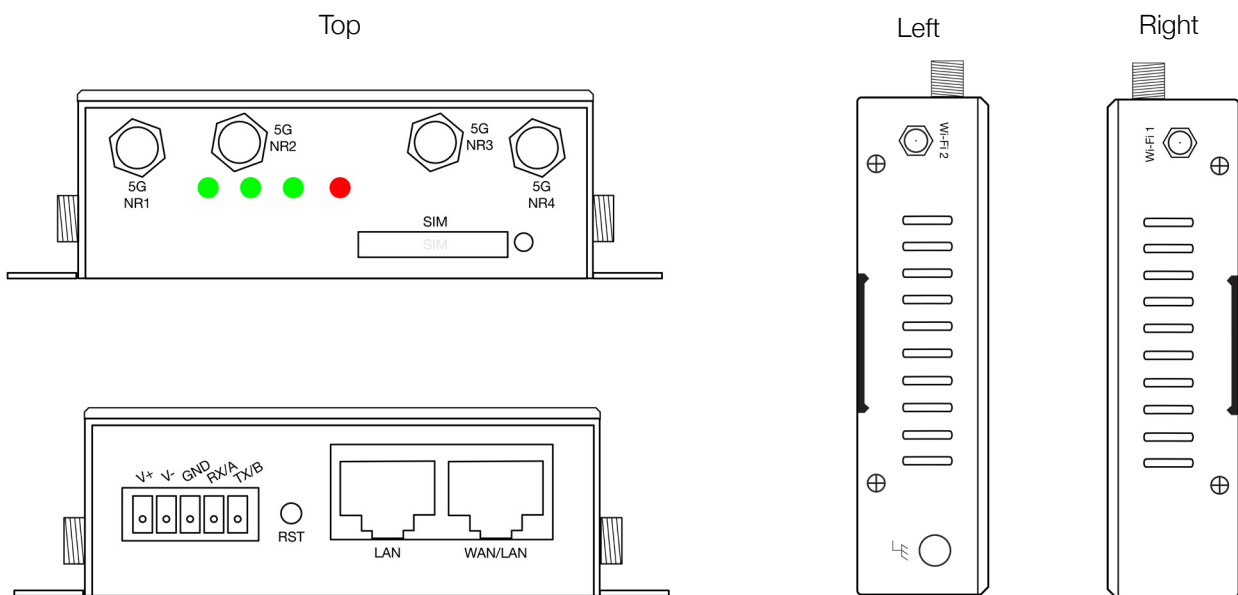

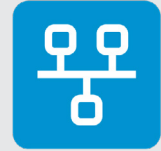

## LAN/WAN Connectors

The Wi-Fi requires two antennas with a 50 Ohm reverse polarity SMA connector meeting the following requirements:

Parameter	Value
VSWR	$\leq 1.5$
Minimum input power	1 W
Frequency range (2.4 GHz band)	2.4 to 2.5 GHz
Frequency range (5 GHz band)	5.15 to 5.85 GHz
Polarization	Vertical
Gain (2.4 GHz band)	3.0 dBi maximum*
Gain (5 GHz band)	3.0 dBi maximum*

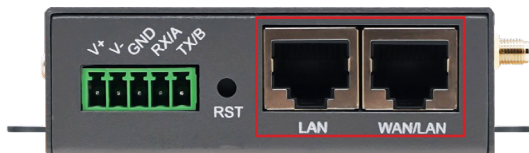

Figure 13. LAN/WAN Connectors (Wi-Fi Version)

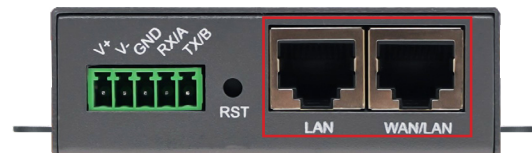
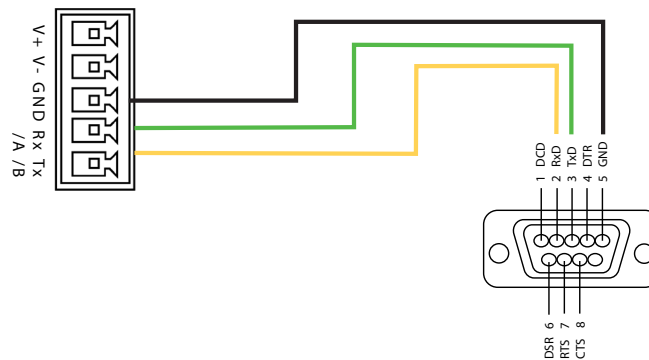

Figure 14. LAN/WAN Connectors (non Wi-Fi version)

\*Note that connecting an antenna exceeding this gain will invalidate this routers compliance with EN 300328 and is not under any circumstances allowed. Siretta takes no responsibility should higher gain antennas be used with this router. The antennas supplied with the optional accessory kit have a gain of 3 dBi and a uniform radiation pattern in the XY plane.

### RS232/RS485 Interface

The RS232/RS485 interface shares the green connector with the power supply.



**Note:** All QUARTZ-GOLD-5G have the RS232 interface. RS485 is an optional feature that must be ordered when the QUARTZ-GOLD-5G is purchased. The serial interface may be switched between RS232 and RS485 using software configuration.:

Pin	Label	Description
1	V+	Power positive
2	V-	Power negative
3	GND	RS232 / RS485 ground
4	RX/A	RS232 RX / RS485 A
5	TX/B	RS232 TX / RS485 B

## Earth Point

There is an earth point on the side of the QUARTZ-GOLD-5G that may be used to earth the router. When the antennas are placed outside of a building it is recommended that the router be earthed as there is always a possibility that the antennas could be struck by lightning. Earthing the router is unlikely to prevent it from receiving catastrophic damage if an antenna receives a lightning strike but should prevent the surge continuing down wiring connected to the router. This reduces both the shock and the fire hazard.



Figure 18. Earth Point

## Reset

The QUARTZ-GOLD-5G can be returned to default settings by pressing and holding down the recessed reset switch while the router is powered.

Three forms of reset are possible depending on how long the reset switch is pressed for until released:

1. 2-10 seconds Router reboot with current settings
2. 10-30 seconds Router reboot with custom reset configuration loaded
3. 30 or more seconds Router reboot with factory default configuration loaded

**Note:** Rebooting with factory default configuration also sets the custom reset configuration back to default.

The custom reset configuration is set up in the software interface. This is a useful mode of operation to return to known working settings rather than full factory reset if the configuration settings are being experimented with.

## SIM Socket

The QUARTZ-GOLD-5G will accept any data enabled SIM card. These may be Pay As You Go (PAYG) or Contract, fixed IP address or normal consumer SIM cards. However, it is recommended that a contract SIM card be used. These are normally shipped ready for use. PAYG SIM cards often need to be activated first in a normal phone before being used in a router.

The SIM card holder is designed to accept a mini-SIM (2FF) (measuring 25 mm x 15 mm). The SIM card voltages supported are 1.8 V and 3.3 V, meaning that the interface will be compatible with any SIM card manufactured after 1998.

Use a small screwdriver or paper clip to press the recessed button to the right of the SIM card holder to release the tray that holds the SIM card and pull out the SIM tray. Place the SIM card into the tray (note polarisation) and insert the SIM tray back into the QUARTZ-GOLD-5G.

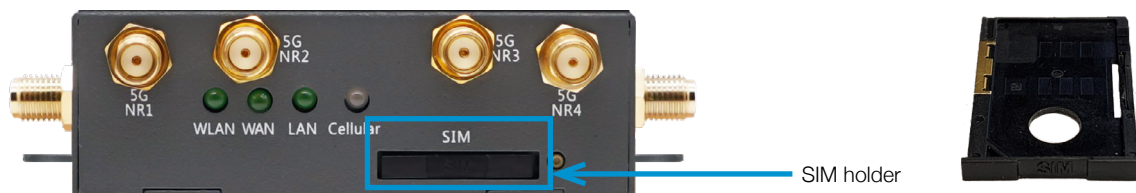

Figure 19. SIM holder

# Antenna Connectors

## Cellular Antenna Connector

The QUARTZ-GOLD-5G is designed for use with 50 Ohm SMA male antennas. Four cellular antennas are required to fully support all the operating bands and data transfer rates. Performance with fewer antennas cannot be easily predicted.

When selecting an antenna, chose an antenna with a frequency band support that matches the frequencies supported by the QUARTZ-GOLD-5G and the chosen network operator. Note that different countries and different network operators support different frequency bands. If in any doubt, do a cellular site survey with one of Siretta's cellular network analysers to find which network operators are present and on which frequency bands they operate.

The selected antenna needs to conform to the following requirements:

Parameter	Value
VSWR	$\leq 3$
Efficiency	$> 30\%$
Input impedance	$50 \Omega$
Cable insertion loss (< 1 GHz)	$< 1 \text{ dB}$
Cable insertion loss (< 1 – 2.3 GHz)	$< 1.5 \text{ dB}$
Cable insertion loss (> 2.3 GHz)	$< 2 \text{ dB}$

The antennas supplied as part of the accessory kit will meet these requirements. Connect the antennas to the inputs marked "5G-1, 5G-2, 5G-3 and 5G-4".



Figure 20. Cellular Antenna Connectors (Wi-Fi Version)



Figure 21. Cellular Antenna Connectors (non-Wi-Fi version)

The antennas should be placed at least 50 cm apart to prevent interference between them provide the best performance. Placing the antennas closer together may result in unnecessary packet re-transmission or even drop out on the cellular connection. Packet re-transmission will be due to transmission errors which not only reduce the effective bandwidth of the cellular connection but may also count against the data allowance provided by the cellular network provider.

### Wi-Fi Antenna Connector

The Wi-Fi requires two antennas with a 50 Ohm reverse polarity SMA connector meeting the following requirements:

Parameter	Value
VSWR	$\leq 1.5$
Minimum input power	1 W
Frequency range (2.4 GHz band)	2.4 to 2.5 GHz
Frequency range (5 GHz band)	5.15 to 5.85 GHz
Polarization	Vertical
Gain (2.4 GHz band)	3.0 dBi maximum*
Gain (5 GHz band)	3.0 dBi maximum*

\*Note that connecting an antenna exceeding this gain will invalidate this routers compliance with EN 300328 and is not under any circumstances allowed. Siretta takes no responsibility should higher gain antennas be used with this router. The antennas supplied with the optional accessory kit have a gain of 3 dBi and a uniform radiation pattern in the XY plane.



Figure 22. Wi-Fi Antenna Connectors

## Power

Power is supplied via a green 5-way 3.50 mm pitch terminal block which also carries the RS232/RS485 connection. The mating connector for the terminal block is Phoenix Contact part number 1840395 or equivalent. All QUARTZ-GOLD-5G models are supplied with an adapter cable consisting of the 5-way connector with power cable fitted (15 cm in length) and a socket so that a power supply with a 2.1 mm Barrel Plug (2.1 x 5.5) can be used to power the QUARTZ-GOLD-5G. A QUARTZ-GOLD-5G purchased with accessories will include a 12 V, 2 A power supply. If using an alternative power supply, this should output at least 24 W of power.



Figure 27. Terminal block to DC power jack adapter supplied with all models

The power connector is shared with that of the RS232 interface. Power should be connected to V+ and V-. The GND terminal is the ground reference for the RS232 connection and should not be used for the power supply connection.

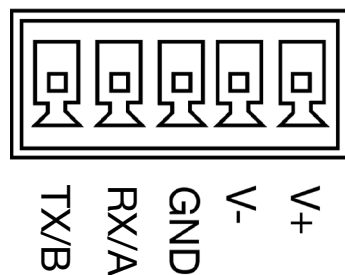



# Copyright Information

## Copyright Declarations

© 2024 Siretta Ltd, all rights reserved

No part of this publication may be reproduced, transmitted, transcribed, stored in a retrieval system, or translated into any language without the written permission of Siretta Ltd.

## Trademarks

Windows and Microsoft are registered trademarks of Microsoft Corporation. Siretta Ltd is an independent business and is neither affiliated with, nor authorized, sponsored, or approved by, Microsoft Corporation.

Snapdragon is a registered trademark of Qualcomm Inc in the United States and other countries.

Quectel is a registered trademark of Quectel Wireless Solutions Co. LTD in the United States and other countries.

Arm and Cortex are registered trademarks of Arm Limited (or its subsidiaries) in the United States and/or elsewhere.

MIPS is a registered trademark of MIPS and MIPS' affiliates as applicable in the United States and other countries.

Sky News is a trademark of Sky International AG in the United States and/or elsewhere.

YouTube is a trademark of Google LLC in the United States and/or elsewhere.

All other trademarks are the property of their respective owners.



## Approvals

- » **CE** - European Conformity
- » **UKCA** - UK Conformity Assessed
- » **RoHS** - Restriction of the Use of Certain Hazardous Substances Compliant
- » **FCC** - (TBC)



## Disclaimer

The information contained in this document is proprietary to Siretta Ltd. Siretta Ltd has made every effort to ensure that the information contained within this document is accurate. Siretta Ltd does not make any warranty as to the information contained within this document and does not accept any liability for any injury, loss or damage of any kind incurred using this information.

Siretta does not take responsibility for any application developed using the product characterized in this document and notes that any application implemented with this product must comply with the safety standards of the applicable country and comply with the relevant wiring rules. Siretta reserves the right to make modifications, additions, and deletions to this document due to typographical errors, inaccurate information, or improvements to equipment at any time and without notice. Such changes will be incorporated into new editions of this document.

Please refer to the [Siretta Ltd](https://www.siretta.com) website for the latest version of this document.

© 2024 Siretta Ltd

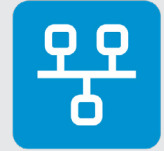

## Definitions

Term	Definition
3G	3rd Generation Mobile Telecommunications
4G	4th Generation Mobile Telecommunications
5G	5th Generation Mobile Telecommunications
ADSL	Asymmetric Digital Subscriber Line
DC	Direct Current
DHCP	Dynamic Host Configuration Protocol
FDD	Frequency Division Duplex
GbE	Gigabit Ethernet
GPS	Global Positioning System
IP	Internet Protocol
LAN	Local Area Network
LED	Light Emitting Diode
LTE	Long-Term Evolution
MDI	Medium Dependent Interface
MIMO	Multiple-input and Multiple-output
RHCP	Right-handed Circular Polarization
RXD	Receive Data
SIM	Subscriber Identity Module
SMS	Short Message Service
TDD	Time Division Duplex
TXD	Transmit Data
UMTS	Universal Mobile Telecommunications System
VPN	Virtual Private Network
VSWR	Voltage Standing Wave Ratio
WAN	Wide Area Network
WLAN	Wireless Local Area Network



Enabling Industrial IoT

**sales** +44 (0)118 976 9000

**email** sales@siretta.com

**www.siretta.com**

Siretta Ltd  
Basingstoke Road  
Spencers Wood  
Reading  
Berkshire  
RG7 1PW  
United Kingdom

Company No. 08405712  
VAT Registration No. GB163 04 0349

